

**SHINDAIWA OWNER'S/OPERATOR'S MANUAL**

**MULTIPURPOSE POLE  
PRUNER TOOL 78702**



**WARNING!**

Minimize the risk of injury to yourself and others!  
Read this manual and familiarize yourself with the  
contents. Always wear eye and hearing protection  
when operating this unit.

## Introduction

The Shindaiwa Pole Pruner tool is designed and built to deliver superior performance and reliability without compromise to quality, comfort, safety or durability.

As an owner/operator, you'll soon discover for yourself why Shindaiwa is simply in a class by itself!

### IMPORTANT!

The information contained in these instructions describes components available at the time of publication.

While every attempt has been made to provide the latest information about your Shindaiwa product, there may be some differences between your attachment and what is described here. Echo, Inc. reserves the right to make changes to products without prior notice and without obligation to make alterations to components previously manufactured.

The procedures described in this manual are intended to help you get the most from your machine as well as to protect you and others from harm. These procedures are guidelines for safe operation under most conditions, and are not intended to replace any safety rules and/or laws that may be in force in your area. If you have questions regarding your power tool, or if you do not understand something in this manual, your Shindaiwa dealer will be glad to assist you.

You may also contact Shindaiwa at the address printed on the back of this manual.

## Contents

	PAGE
Introduction .....	2
Attention Statements .....	2
Safety Precautions.....	2
Operating Precautions .....	3
Safety Labels.....	4
Operating the Pruner .....	4
Product Description.....	5
Specifications.....	6
Assembly.....	6
Filling the Chain Oiler Reservoir .....	8
Maintenance .....	9
Sharpening the Chain .....	10
Troubleshooting Guide .....	12

## Attention Statements

Throughout this manual are special attention statements.

### DANGER!

A statement preceded by the triangular attention symbol and the word "DANGER" indicates an imminently hazardous situation which, if not avoided, WILL result in death or serious injury!

### WARNING!

A statement preceded by the triangular attention symbol and the word "WARNING" indicates a potentially hazardous situation which, if not avoided, COULD result in death or serious injury.

### CAUTION!

A statement preceded by the word "CAUTION" contains information that should be acted upon to avoid damage to the machine.

### IMPORTANT!

A statement preceded by the word "IMPORTANT" is one that possesses special significance.

### NOTE:

A statement preceded by the word "NOTE" contains information that is handy to know and may make your job easier.



Read and follow this manual, make sure anyone using the trimmer does likewise. Failure to do so could result in serious personal injury or machine failure. Keep this manual for future reference.



Always wear a hard hat to reduce the risk of head injuries during operation of this machine. In addition, always wear eye and hearing protection. Shindaiwa recommends wearing a face shield as additional face and eye protection.



Wear heavy duty, non-slip gloves.



Safety tip shoes or boots with non-slip sole should be worn.

## Safety Precautions

### WARNING!

**THE PRUNER IS NOT INSULATED AGAINST ELECTRICAL SHOCK!** Approaching or contacting electrical line with the pruner could cause death or serious injury. Keep the pruner at least 33 feet (10 meters) away from electrical lines or branches that contact electrical lines.

### NOTE:

For specific maintenance and safety information about your Multipurpose Tool Carrier, consult the owner's manual provided with it. If it has been lost or misplaced, contact a Shindaiwa dealer for a replacement.

### WARNING!

A pole pruner runs at very high speeds and has the potential to do serious damage if misused, abused or mishandled. To reduce the risk of injury, you must maintain control at all times, and observe all safety precautions during operation. **Never permit a person without training or instruction to operate this pruner!**



This product conducts electricity. Keep the product and/or operator a minimum distance of 15 feet (4.5 meters) away from electrical sources and power lines.



Keep bystanders at least 50 feet (15 meters) away from the operating trimmer to reduce the risk of being struck by falling objects or thrown debris.



The blades / cutting attachments are SHARP! Handle with care.



Be aware of the danger of falling debris.

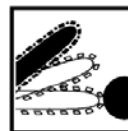

### Beware of Kickback!

Kickback can occur whenever the tip of the guide bar touches an object while the saw is operating. Kickback may force the bar up and back toward the operator with lightning-like speed!

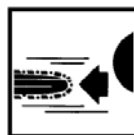

### Beware of pinching.

Pinching the saw along the tip of the guide bar may force the bar back rapidly toward the operator. Pinching can occur whenever wood closes in around the moving chain.

## CAUTION!

- Always maintain the Multipurpose Pole Pruner Tool according to this owner's manual and follow the recommended scheduled maintenance.
- Never modify or disable any of the pruner's safety devices.
- Always use genuine Shindaiwa parts and accessories when repairing or maintaining this machine.
- Do not make unauthorized modifications to the pole pruner.
- When transporting the pole pruner in a vehicle, tie it down securely to prevent fuel spillage or damage to the machine.
- Always clear your work area of trash or hidden debris to help ensure good footing.
- Keep the chain sharp and properly adjusted.
- Keep the pole pruner as clean as possible. Keep it free of loose vegetation, mud, debris, etc.

## Operating Precautions



### WARNING!

- This Shindaiwa pole pruner tool is specifically designed for use on the Shindaiwa Multipurpose Tool Carrier. Installation and/or use on any other model, brand or type of power tool is not approved by Shindaiwa. Attempts to use on non-approved models can damage the equipment and cause accidents, serious injury or death.
- Make sure the chain and sprocket are correctly adjusted before operating the pruner (see for adjustment procedures). **Never attempt chain adjustment with the engine running!**
- Always make sure the cutting attachment is properly installed and firmly tightened before operation.
- Never use a cracked or warped guide bar: replace it with a serviceable one and make sure it fits properly.
- If a saw blade should bind fast in a cut, shut off the engine immediately. Push the branch or tree to ease the bind and free the blade.
- Before starting the engine, make sure the saw chain is not contacting anything.
- When cutting a limb that is under tension, be alert for springback so that you will not be struck by the moving limb.
- Always run at wide open throttle (WOT) before contacting material to be cut.
- Always stop the engine immediately and check for damage if you strike a foreign object or if the machine becomes tangled. Do not operate with broken or damaged equipment.
- Stop the machine immediately if it suddenly begins to vibrate or shake. Inspect for broken, missing or improperly installed parts or attachments.
- Never transport the pruner or set it down with the engine running. An engine that's running could be accidentally accelerated causing the chain to rotate.
- Make sure the scabbard is in place when transporting the pruner.
- When carrying by hand, the chain should be pointing backward.

## Safety Labels

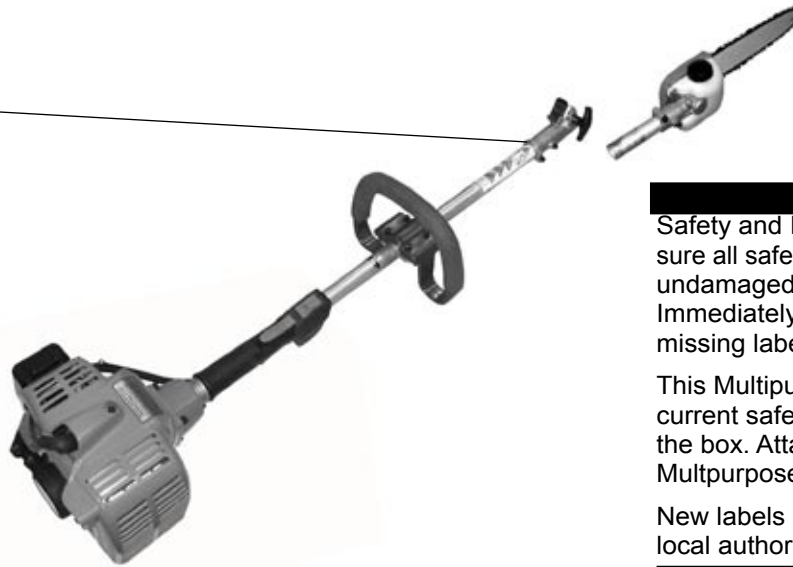
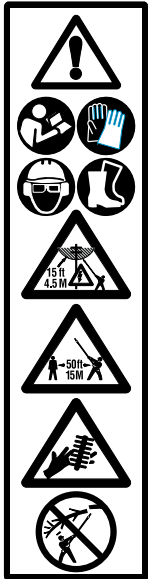

### **IMPORTANT!**

Safety and Information Labels: Make sure all safety and information labels are undamaged, readable and up to date. Immediately replace damaged or missing labels.

This Multipurpose Tool comes with a current safety label shipped loose in the box. Attach this safety label on the Multipurpose Tool Carrier.

New labels are available through your local authorized Shindaiwa dealer.

## Operating the Pruner



### **WARNING!**

To avoid the chance of serious injury or death, follow these safety precautions during operation:

*Always wear a hard hat to reduce the risk of head injuries during operation of this machine.*

*Wear nonslip heavy-duty work gloves to improve your grip on the pole pruner handle. Wear snug-fitting clothes that also permit freedom of movement. NEVER wear shorts!*

*Keep a proper footing and do not overreach—maintain your balance at all times during operation.*

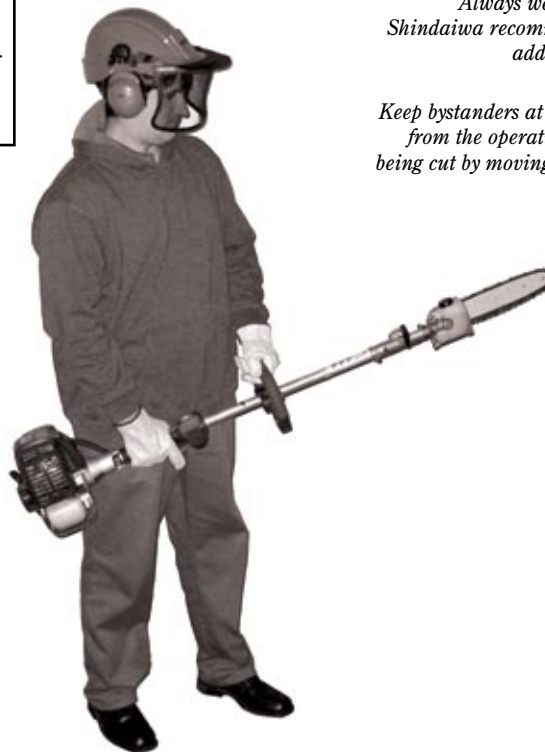

*Always wear eye and hearing protection. Shindaiwa recommends wearing a face shield as additional face and eye protection.*

*Keep bystanders at least 50 feet (15 meters) away from the operating pruner to reduce the risk of being cut by moving saw chain or struck by falling objects or thrown debris.*

*Never operate the pruner at an angle greater than 60° in order to reduce the risk of being struck by falling objects during operation.*

*Always operate with both hands firmly gripping the machine.*

*Wear sturdy footwear with nonslip soles to provide good footing. Steel-toed safety boots are recommended. Never operate this product barefoot.*

# Kickback and Pinching Safety Precautions

Both kickback and pinching may cause you to lose control of the pole pruner tool which could result in serious personal injury. **Do not rely exclusively on the safety device built into the pruner!** You must take several steps to keep your jobs free from accident or injury:

1. Understand kickback and pinching! You can reduce or eliminate the element of surprise. Sudden surprises contributes to accidents.



### Beware of Kickback!

Kickback can occur whenever the tip of the guide bar touches an object while the saw is operating. Kickback may force the bar up and back toward the operator with lightning-like speed!



### WARNING!

2. Keep a firm grip on the pole pruner with both hands whenever the engine is running. A firm grip will help you reduce the affects of kickback and pinching as well as maintain control of the machine.
3. Make sure the area in which you are cutting is free from obstructions. Do not let the nose of the guide bar contact a log, branch, or any other obstructions which could be hit while you operate the pole pruner tool.

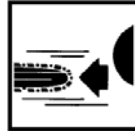

### Beware of pinching.

Pinching the saw along the tip of the guide bar may force the bar back rapidly toward the operator. Pinching can occur whenever wood closes in around the moving chain.

4. Cut at high engine speeds.
5. Follow the manufacturer's instructions for sharpening and maintaining the chain.
6. Use only the replacement bar and chain or equivalent as specified by the manufacturer.

## Product Description

### Prior To Assembly

Familiarize yourself with the Shindaiwa pole pruner tool and its various components. Understanding your machine helps ensure top performance, longer service life, and safer operation.

Before assembling, make sure you have all the components required for a complete unit:

- Gearcase assembly/Cutting Head
- Guide Bar
- Saw Chain
- Scabbard
- Owner's/Operator's manual
- Assembly Tool (s)
- Safety Label

Carefully inspect all components making sure they are not damaged.

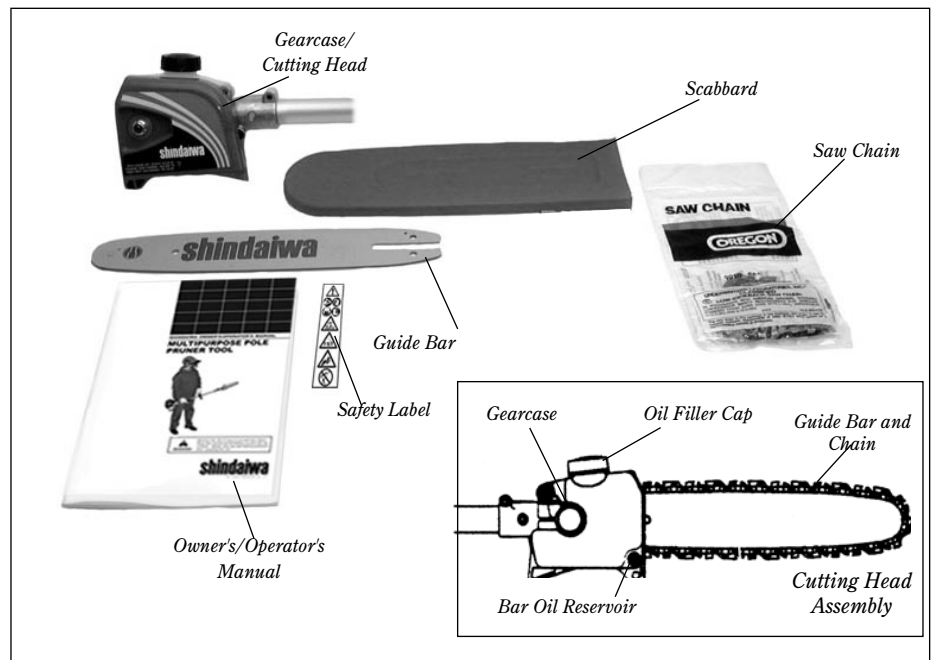

### IMPORTANT!

The terms "left", "left-hand", and "LH"; "right", "right-hand", and "RH"; "front" and "rear" refer to directions as viewed by the operator during normal operation.



### WARNING!

Do not make unauthorized modifications or alterations to your pole pruner or its components.

## Specifications

Length .....	222 mm (8.7 in)	Chain Type.....	3/8" pitch Micro Lite™, .043" gauge
Width.....	74 mm (2.9 in)	Sprockets.....	3/8-inch, fixed spur
Height.....	116 mm (4.6 in)	Gearcase Ratio.....	1.06 : 1
Dry Weight (Tool only) without bar and chain.....	0.7 kg (1.5 lbs)	Chain Lubrication.....	Automatic adjustable oiler
Guide Bar.....	3/8" pitch, .043" gauge, 10-inch Micro Lite™	Oil Tank Capacity.....	100 ml./3.9 oz.

Specifications are subject to change without notice.

## Assembly

### Installing a Tool Attachment

1. Place the Multipurpose Tool Carrier (A) and the Tool Assembly (B) on a clean, flat surface so that both assemblies fit end to end. The powerhead assembly should be facing up, and the tool assembly should be positioned with the locking hole in the tube (C) end facing up.

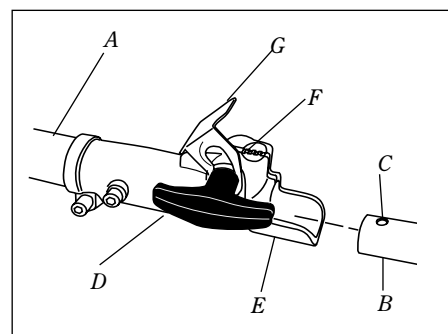

#### **CAUTION!**

Keep the open ends of the tubes clean and free of Debris!

2. Slip off the protective cover from the end of the tool, and loosen the coupler screw knob (D).
3. Insert the tool assembly into the coupler (E), with the tool decal facing up, until the line of the decal is flush with the end of the coupler. Twist the tool back and forth until you are sure it snaps in place by the coupler latch (F).
4. When the two tube halves are locked together, press down on the spring-loaded latch protector (G) and tighten the coupler screw knob.

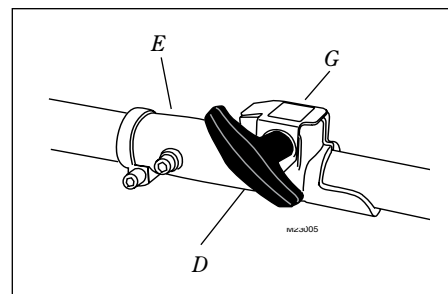

### Disassembling The Pole Sections

1. Place the Multipurpose Tool Carrier and the Tool Assembly on a clean, flat surface, loosen the coupler screw knob (D). The spring-loaded coupler protector (G) should pop up.
2. Press down on the latch (F) with your finger or thumb. This releases the coupler latch.
3. Pull the tool assembly (B) out of the coupler (E).

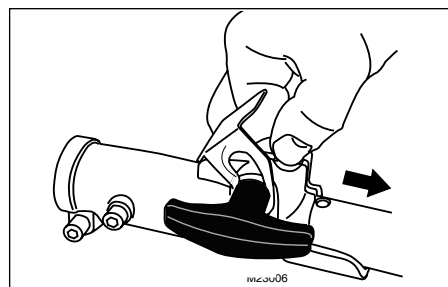

# Installing and Adjusting the Bar and Chain

## Installing The Chain



### WARNING!

Never attempt to install, replace, or adjust the chain with the engine running.



### WARNING!

The saw chain is very sharp. Wear gloves to protect your hands when handling.

### NOTE:

For the longest chain life, let new or replacement chain loops soak in oil overnight before installation.

1. Using the small end of the plug wrench, remove the sprocket cover nut (A) (turn counterclockwise to remove) and remove the sprocket cover (B).

### CAUTION!

Failure to align the guide bar and chain tensioning pin can cause serious damage to the sprocket cover, guide bar, chain tensioning pin and cutting head assembly.

2. Place the guide bar (C) over the guide bar adjustment stud (D) on the cutting head assembly. Align the chain tensioning pin (E) with the hole in the guide bar.
3. Install the chain loop over the drive links within the guide bar groove, and then align the chain over the drive sprocket. Make sure the cutters are properly oriented as shown. If the chain installation is difficult or if the chain appears too tight, refer to the section "Adjusting the Chain."



### WARNING!

Never operate the pole pruner tool without the sprocket cover installed.

4. Install the sprocket cover over the bar stud. Using finger-pressure only, install the sprocket cover nut.
5. Refer to the next page for chain adjusting procedures.

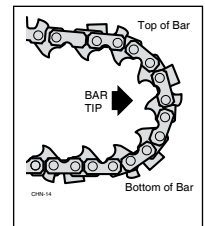
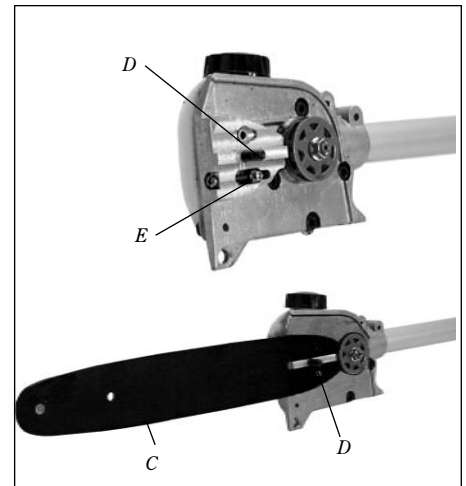
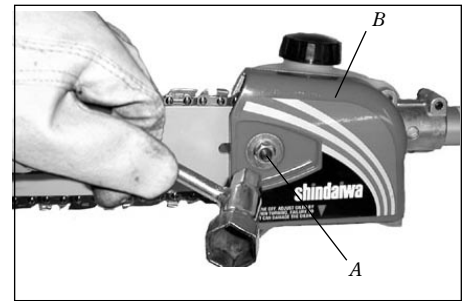

## Adjusting the Chain



### WARNING!

Never attempt to install, replace, or adjust the chain with the engine running.



### WARNING!

The saw chain is very sharp. Wear gloves to protect your hands when handling.

### CAUTION!

A loose chain can jump off the guide bar causing damage to the chain and associated equipment. Always make sure the chain is properly adjusted; check more often when you are breaking in a new chain.

### IMPORTANT!

Proper chain adjustment is essential for maximum performance, long chain life, and operator safety. Always inspect chain tension before operating the pole pruner tool.

1. Place the pole pruner on a clean, flat surface. (For readjustment during operation, shut down the engine, then allow the guide bar and chain to cool before proceeding with the adjustment procedure).
2. Loosen the sprocket cover nut (A) with the plug wrench.
3. Lift the nose of the guide bar while turning the chain tensioning screw (B).
  - clockwise to tighten the chain
  - counter clockwise to loosen the chain.
4. Pull the chain by hand along the top of the guide bar several times from the engine to the bar's tip. The chain should feel snug but still pull freely.
5. Tighten the sprocket cover nut securely while lifting the tip of the guide bar.
6. Inspect the chain for the correct adjustment (more frequently with a new chain). The chain should feel snug but still pull freely.

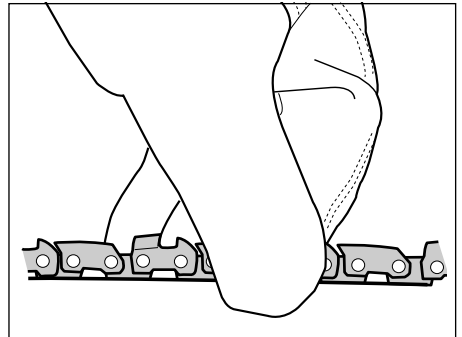
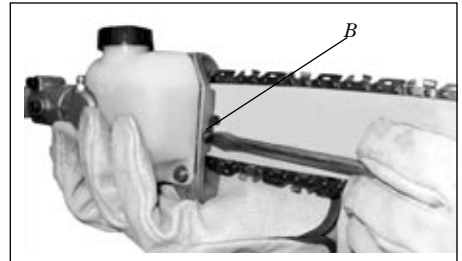
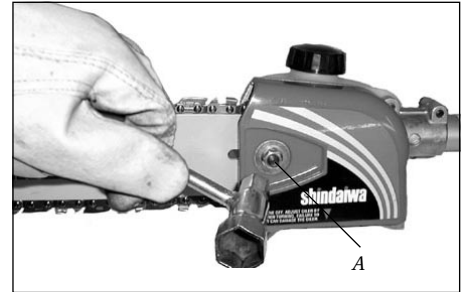

## Filling the Chain Oiler Reservoir



### WARNING!

Never fill the oil reservoir or adjust the oiler with the engine running.

### IMPORTANT!

To prevent plastic deterioration, do not use synthetic or silicone based oil.

1. Place the pole pruner tool on a clean, flat surface with the oil filler cap (C) facing up. Wipe off any debris from the oil cap and from around the oil filler neck.
2. Remove the oil filler cap (C) and fill the reservoir with bar and chain oil, then replace the cap.
3. Wipe up any spilled oil from the unit before restarting the pole pruner.

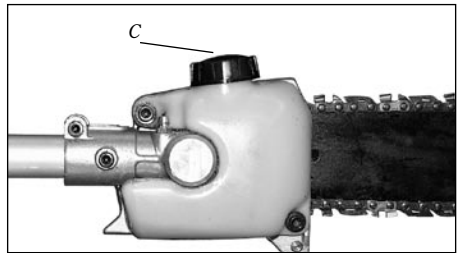

## Adjusting Oil Flow Rate

### NOTE:

The automatic oiler is preset to deliver a sufficient oil discharge volume during normal operating conditions. During heavy or dry cutting conditions, the oil discharge volume may be increased to assure adequate lubrication. If oil is leaking from the bar cover area, reduce the oil discharge volume. Refill the oil reservoir with each tank of fuel.

### NOTE:

Very little visible oil on the saw chain will provide sufficient lubrication.

Adjust the pump as follows:

1. Stop the engine and make sure the stop switch is in the OFF position.
2. Place the unit on its side with the oil reservoir (D) up.
3. Using a screwdriver, turn the oil flow rate adjustment screw (E) in the desired direction:
  - clockwise—decrease lubrication.
  - counter clockwise—increase lubrication.

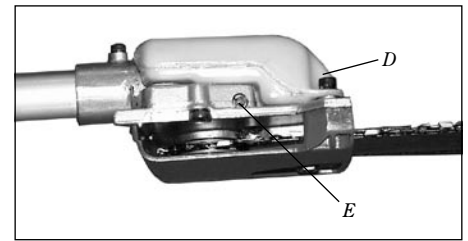

## Using the Pole Pruner

This machine is designed especially for cutting branches.

Never use this machine for any other purpose. Never try to cut stones, metals, plastics, or any other hard objects.

Using for purposes other than cutting branches may damage the machine or cause serious injury.

### Preparations

- Wear suitable protective clothing and equipment – see section “Safety Precautions”.
- Choose the best work position for safety against falling objects such as branches.
- Start the engine.
- Put on the strap.

Never stand directly underneath the branch you are cutting – be aware of falling branches. Note that a branch may spring back at you after it hits the ground.

### Cutting Sequence:

To allow branches to fall freely, always cut the bottom branches first. Prune heavy branches (large in diameter) in several controllable pieces.

### Working Position:

Hold the control handle with your right hand and the shaft with your left hand. Your left arm should be extended to the most comfortable position.

**The shaft should always be held at an angle of 60° or less.**

### Standard Cut:

The most convenient working position is a tool angle of 60°, but any other angle may be used to suit the situation.

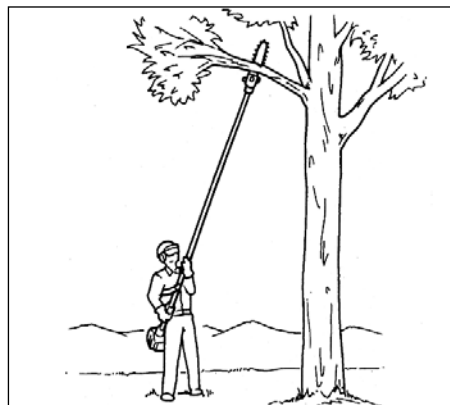

### Cutting Above Obstacles:

Thanks to the unit's long reach it is possible to prune branches that are overhanging obstacles such as rivers or lakes. The tool angle in this case depends on the position of the branch.

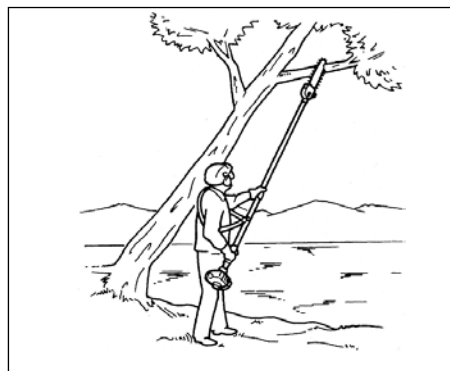

### Cutting On A Work Platform:

The unit's long reach enables cutting to be performed next to the trunk without the risk of the work platform damaging other branches. Tool angle in this case depends on the position of the branch.

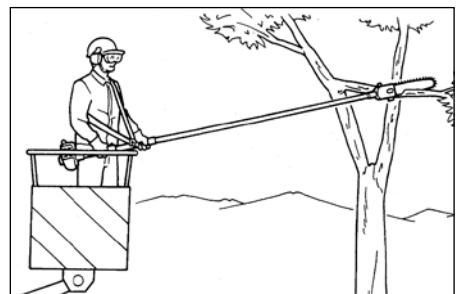

### Relieving Cut:

To avoid tearing the bark, kickback or pinching the bar when pruning thick branches, always start by performing a relieving cut (1) on the underside of the branch.

To do this, apply the cutting attachment and pull it across the bottom of the branch as far as the bar nose. Perform the cross-cut (2).

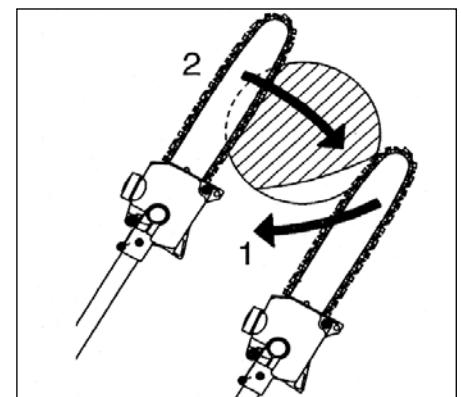

## Flush-cutting Thick Branches:

If branch diameter is more than 10 cm, first perform undercut (3) and cross-cut at a distance (A) of about 25 cm from the final cut. Then carry-out the flush-cut (4), starting with a relieving cut and finishing with a cross-cut.

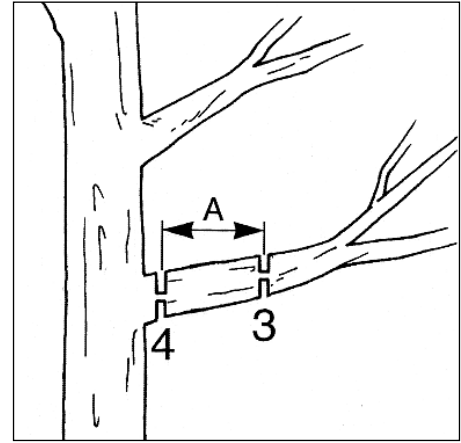

## Maintenance

### IMPORTANT!

For detailed maintenance information about your Multipurpose Tool Carrier, consult the owner's manual that was provided with it. If it has been lost or misplaced, contact Shindaiwa for a replacement.



### WARNING!

Before performing any maintenance, repair, or cleaning work on the unit, make sure the engine and cutting attachment are completely stopped. Disconnect the spark plug wire before performing service or maintenance work.



### WARNING!

Non-standard parts may not operate properly with your unit and may cause damage and lead to personal injury.

### IMPORTANT!

Using non-standard replacement parts could invalidate your Shindaiwa warranty.

## Daily Maintenance



### WARNING!

The saw chain is very sharp. Wear gloves to protect your hands when working with or around the saw chain.

Prior to each work day, perform the following:

- Clean any debris or dirt from the cutting attachment. Check the bar and chain for damage or incorrect adjustment.
- Check for loose or missing screws or components. Make sure the cutting attachment is clean, free of debris and securely fastened.
- Check the entire machine for leaking fuel or grease.
- Make sure that nuts, bolts, and screws (except carburetor adjusting screws) are tight.

## 15-hour Maintenance

### Every 15 hours of operation

(more frequently in dusty or dirty conditions):

- Remove the sprocket cover and inspect the sprocket (A) for excessive dirt, debris, or wear. Remove the guide bar and clean out the guide bar groove. If the sprocket is excessively worn, replace it with a new one.

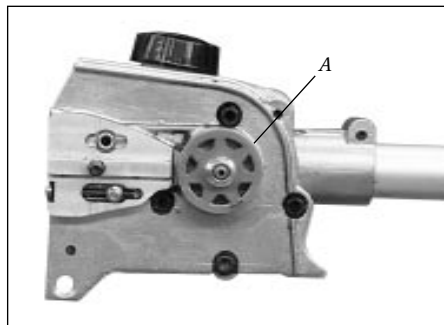

## 50-hour Maintenance

Every 50 hours of operation (more frequently in dusty or dirty conditions):

- **Lubricate the gearcase.** To perform this operation, first remove the gearcase from the upper outer tube as follows.

### CAUTION!

Do not remove the D-shaped shim washer from the gearcase clamp! The shim washer prevents damage from overtightening the tube clamp screw.

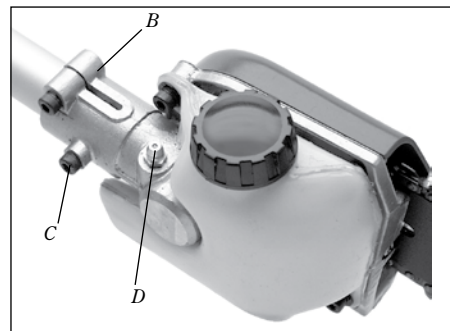

- loosen the gearcase clamp bolt (B).
- remove the index bolt (C) from the gearcase.
- slide the gearcase out of the tube.
- Using a lever-type grease gun, pump lithium-base grease (about 10 grams) into the grease fitting (D) until you see old grease being purged from the gearcase, which can be seen in the outer tube cavity. Clean up excess grease, then reassemble the gearcase onto the outer tube.

## Sharpening the Chain

- When the cutting edges of the blade become dull, they can be re-sharpened with a few strokes of a file.
- In order to keep the blade in balance, all cutting edges must be sharpened equally.
- In addition, inspect the chain for correct adjustment (more frequently with a new chain). The chain should feel snug but still pull freely. Refer to adjustment procedures.

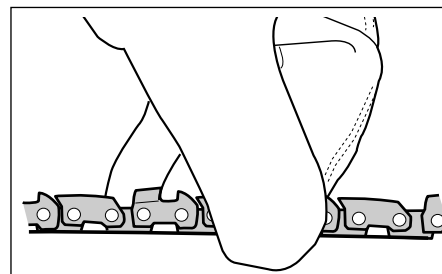

### CAUTION!

Keep the chain sharp and properly adjusted.



### WARNING!

The saw chain is very sharp. Wear gloves to protect your hands when working with or around the saw chain.

## Sharpening Instructions

### IMPORTANT!

File all the cutters to the same angle and depth! Unequal filing may cause the saw to vibrate or cut erratically!

1. Using a 4.5 mm round file, sharpen all cutters to a 30° angle. Make sure that one fifth (20%) of the file's diameter is always held above the cutter's top plate.
2. After all cutters are sharpened, use a depth gauge joiner (A) to measure the height of each depth gauge.
3. As required, lower the depth gauges to a height of 0.025 inch. Use a flat file.
4. After all depth gauges have been adjusted, use a flat file to round each depth gauge leading edge to its original curvature and angle.

### NOTE:

For consistent filing angles, use a filing guide.

### NOTE:

See specification page for replacement bar and chain specs.

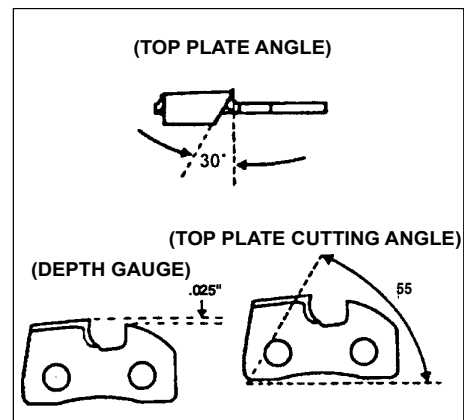
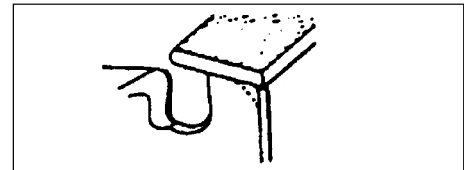
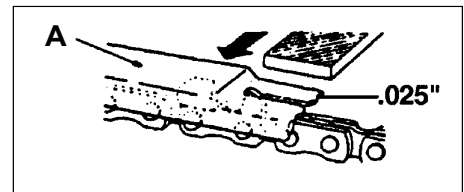
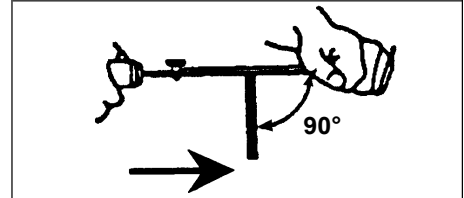
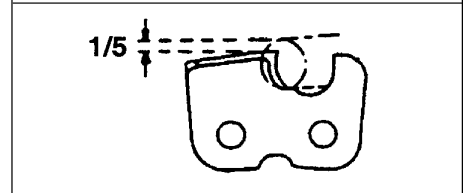
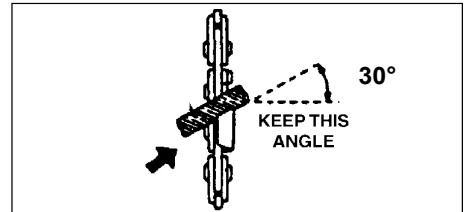

# Troubleshooting Guide

## ADDITIONAL PROBLEMS

Symptom	Possible Cause	Remedy
<b>Excessive vibration.</b>	Warped or damaged attachment. Loose gearcase. Bent main shaft/worn or damaged bushings.	Inspect and replace attachment as required. Tighten gearcase securely. Inspect and replace as necessary.
<b>Chain will not rotate.</b>	Shaft not installed in powerhead or gearcase. Broken shaft. Damaged gearcase.	Inspect and reinstall as required. Consult with an authorized Shindaiwa servicing dealer.
<b>Chain rotates at idle speed.</b>	Engine idle too high. Broken clutch spring or worn clutch spring boss.	Adjust idle. Check Specifications page for correct idle speed. Replace spring/shoes as required, check idle speed.





## **Servicing Information**

### **Parts/Serial Number**

Genuine Shindaiwa Parts and Assemblies for your Shindaiwa products are available only from an Authorized Shindaiwa Dealer. When you do need to buy parts **always** have the Model Number, Type and Serial Number of the unit with you. You can find these numbers on the engine. For future reference, write them in the space provided below.

Model No. \_\_\_\_\_ SN. \_\_\_\_\_

### **Service**

Service of this product during the warranty period must be performed by an Authorized Shindaiwa Service Dealer. For the name and address of the Authorized Shindaiwa Service Dealer nearest you, ask your retailer or call: 1-877-986-7783. Dealer information is also available on [WWW.SHINDAIWA.COM](http://WWW.SHINDAIWA.COM). When presenting your unit for Warranty service/repairs, proof of purchase is required.

### **Consumer Product Support**

If you require assistance or have questions concerning the application, operation or maintenance of this product you may call the Shindaiwa Consumer Product Support Department at 1-877-986-7783 from 8:30 am to 4:30 pm (Central Standard Time) Monday through Friday. Before calling, please know the model and serial number of your unit.

### **Warranty Registration**

To ensure trouble free warranty coverage it is important that you register your Shindaiwa equipment by filling out the warranty registration card supplied with your unit. Registering your product confirms your warranty coverage and provides a direct link if we find it necessary to contact you.

### **Additional or Replacement Manuals**

Replacement Operator and Parts Catalogs are available from your Shindaiwa dealer or at [WWW.SHINDAIWA.COM](http://WWW.SHINDAIWA.COM) or by contacting the Consumer Product Support Department (1-877-986-7783). Always check [WWW.SHINDAIWA.COM](http://WWW.SHINDAIWA.COM) for updated information.

# **shindaiwa®**

ECHO Incorporated.  
400 Oakwood Road  
Lake Zurich, IL 60047-1564 U.S.A.  
Telephone: 1-877-986-7783  
Fax: 1-847-540-8416  
[www.shindaiwa.com](http://www.shindaiwa.com)

Yamabiko Corporation  
7-2 Suehirocho 1-Chome, Ohme,  
Tokyo, 198-8760, Japan  
Phone: 81-428-32-6118  
Fax: 81-428-32-6145