

**SHINDAIWA OWNER'S/OPERATOR'S MANUAL**

# **PB270 POWERBROOM**

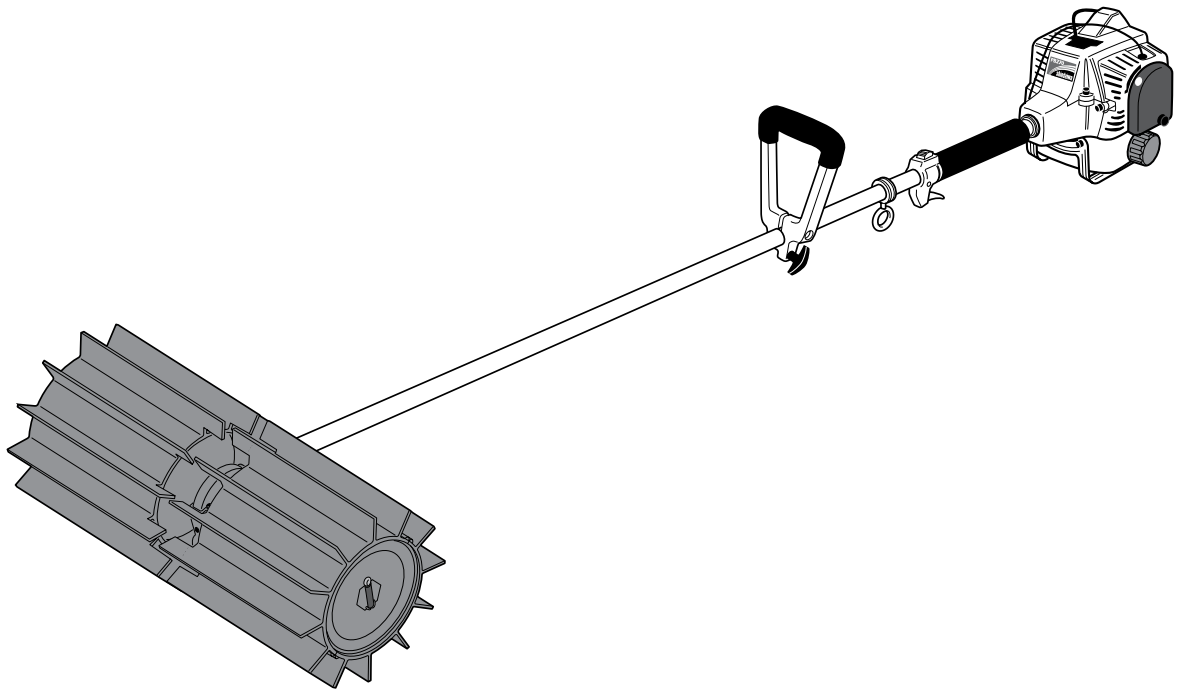

**WARNING!**

Minimize the risk of injury to yourself and others! Read this manual and familiarize yourself with the contents. Always wear eye and hearing protection when operating this unit.

**X7502235300  
05/10**

**shindaiwa®**

# Introduction

The Shindaiwa PB270 PowerBroom is designed and built to deliver superior performance and reliability without compromise to quality, comfort, safety or durability.

Shindaiwa engines represent the leading edge of high-performance engine technology, delivering exceptionally high power with remarkably low displacement and weight. As an owner/operator, you'll soon discover for yourself why Shindaiwa is simply in a class by itself!

## IMPORTANT!

The information contained in these instructions describes units available at the time of publication.

Echo, Inc. reserves the right to make changes to products without prior notice, and without obligation to make alterations to units previously manufactured.



## WARNING!

The engine exhaust from this product contains chemicals known to the State of California to cause cancer, birth defects or other reproductive harm.

# Contents

	PAGE		PAGE		PAGE
Safety .....	3	Filling the fuel tank .....	8	Operating .....	11
Product Description .....	5	Starting the Engine .....	9	Maintenance .....	12
Specifications .....	5	Stopping the Engine .....	10	Long Term Storage .....	15
Assembly .....	6	Adjusting Engine Idle .....	10	Troubleshooting Guide .....	16
Mixing fuel .....	8	Checking Unit Condition .....	10	Warranty Statement .....	19

## IMPORTANT!

The operational procedures described in this manual are intended to help you get the most from this unit as well as to protect you and others from harm. These procedures are guidelines for safe operation under most conditions, and are not intended to replace any safety rules and/or laws that may be in force in your area. If you have questions regarding your PowerBroom, or if you do not understand something in this manual, contact your local authorized Shindaiwa dealer. You may also contact Shindaiwa Inc. at the address printed on the back of this Manual.

# Attention Statements

Throughout this manual are special "attention statements".



**DANGER!**

A statement preceded by the triangular attention symbol and the word "DANGER" contains information that should be acted upon to prevent serious injury or death.



**WARNING!**

A statement preceded by the triangular attention symbol and the word "WARNING" contains information that should be acted upon to prevent serious bodily injury.

**CAUTION!**

A statement preceded by the word "CAUTION" contains information that should be acted upon to prevent mechanical damage.

**IMPORTANT!**

A statement preceded by the word "IMPORTANT" is one that possesses special significance.

**NOTE:**

A statement preceded by the word "NOTE" contains information that is handy to know and may make your job easier.

# Warning and operational labels



Read and follow this manual, make sure anyone using the pruner does likewise. Failure to do so could result in serious personal injury or machine failure. Keep this manual for future reference.



Beware of thrown objects. Keep bystanders at least 15 M (50 feet) away during operation.



Always wear a hard hat to reduce the risk of head injuries during operation of this machine. In addition, always wear eye and hearing protection. Shindaiwa recommends wearing a face shield as additional face and eye protection.



Do not use on unguarded elevated surfaces.



Maintain a shallow working angle and avoid moving toward the vertical.

# Safety

## Work Safety

A PowerBroom operates at very high speeds and has the potential to do serious damage if misused, abused or mishandled. To reduce the risk of injury, you must maintain control at all times, and observe all safety precautions during operation. Never permit a person without training or instruction to operate this machine!

 **WARNING!**  
Never make unauthorized attachment installations.

### Stay Alert

You must be physically and mentally fit to operate this unit safely.

 **WARNING!**  
Never operate power equipment of any kind if you are tired or if you are under the influence of alcohol, drugs, medication or any other substance that could affect your ability or judgement.



 **WARNING!**  
**Use Good Judgement**

- Sweeper belts may move when starting engine. Place sweeper belts on a smooth level surface when starting.
- Always make sure the PowerBroom attachment is properly installed and firmly tightened before operation.
- Always wear eye protection to shield against thrown objects.
- Never modify or disable any of the unit's safety devices.
- Do not make unauthorized modifications to this unit.
- Make sure there are no missing or loose fasteners, and that the ignition switch and throttle controls are working properly.
- Do not operate the unit with the muffler removed.
- NEVER operate this unit indoors. Operate this unit only in a well ventilated area. Be aware of carbon monoxide poisoning. Exhaust gases and lubrication oil mist can cause serious injury or death.
- Always hold the machine firmly with both hands when sweeping, and maintain control at all times.
- Always stop the engine immediately and check for damage if you strike a foreign object or if the unit becomes tangled. Do not operate with broken or damaged equipment.
- Always clear your work area of trash or hidden debris to help ensure good footing.
- Always use genuine Shindaiwa parts and accessories when repairing or maintaining this unit.
- Stop the unit immediately if it suddenly begins to vibrate or shake. Inspect for broken, missing or improperly installed parts or attachments.
- Never transport the unit nor set it down with the engine running. An engine that's running could be accidentally accelerated causing the drum assemblies to rotate.
- Always disconnect the spark plug wire before performing any maintenance work.
- Always maintain this unit according to this owner's manual and follow the recommended scheduled maintenance.

## Safety Labels

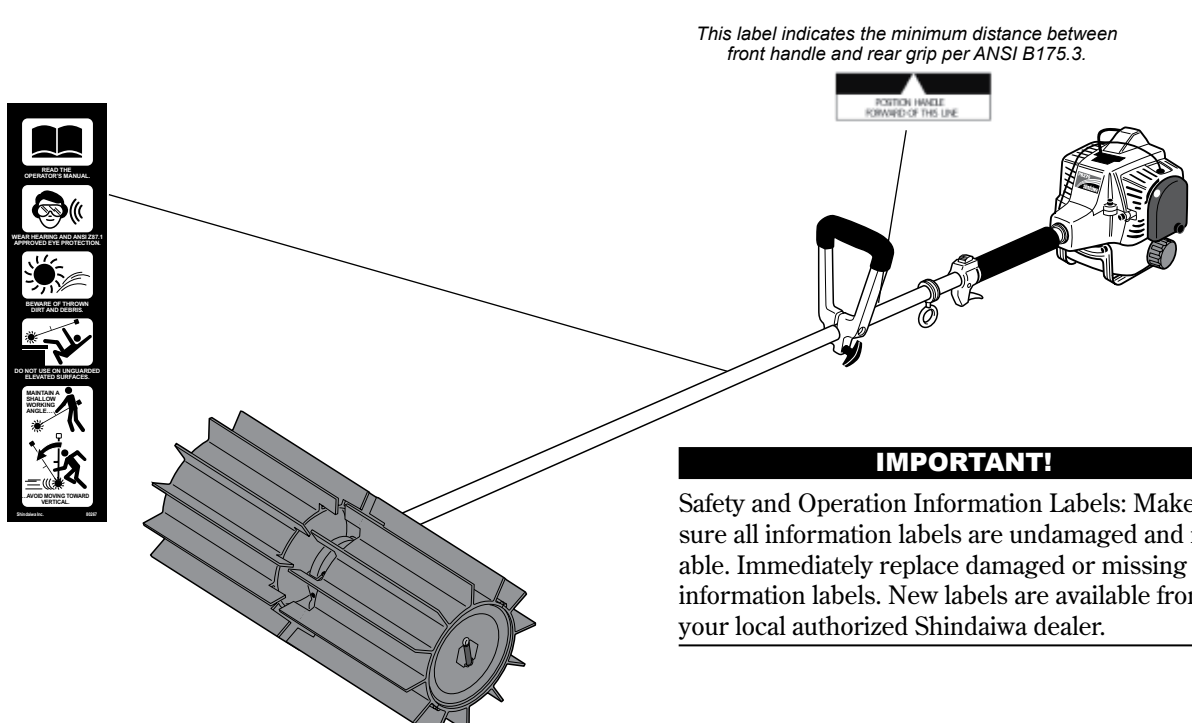

*This label indicates the minimum distance between front handle and rear grip per ANSI B175.3.*

**IMPORTANT!**

Safety and Operation Information Labels: Make sure all information labels are undamaged and readable. Immediately replace damaged or missing information labels. New labels are available from your local authorized Shindaiwa dealer.

**Labels shown in the diagram:**

- READ THE OPERATOR'S MANUAL
- WEAR HEARING AID AND USE APPROVED EYE PROTECTION
- AVOID CONTACT WITH SPINNING DRUMS AND BELTS
- DO NOT USE ON UNGUARDED SLIPPERY SURFACES
- MAINTAIN A SMOOTH WORKING SURFACE
- AVOID MOVING TOWARD OTHERS

**Positioning label:** POSITION HANDLE FORWARD OF THIS LINE

## Safety (continued)

### The Properly Equipped Operator

Always protect yourself from hazards such as thorny brush and flying debris by wearing gloves and close fitting clothing that covers arms and legs. Never wear shorts. Don't wear loose clothing or items such as jewelry that could get caught in machinery or underbrush. Secure long hair so it is above shoulder level.

Keep a proper footing and do not overreach—maintain your balance at all times during operation.

Wear sturdy footwear with nonslip soles to provide good footing. Steel-toed safety boots are recommended. Never operate unit bare-footed!



Always wear eye and hearing protection. Shindaiwa recommends wearing a face shield as additional face and eye protection.

Always operate with both hands firmly gripping the unit.

Keep away from rotating sweeper belts or bristles at all times, and NEVER lift a moving attachment above waist-height.

### Be Aware of the Working Environment

Be careful when operating on a slope or on slippery terrain, especially during rainy weather or when pulling debris toward you.

If the drum assemblies jam, switch the engine OFF and inspect the drums, axles and gearcase for damage.

Do not use this unit on rooftops or elevated surfaces

When transporting the unit in a vehicle, tie it down securely to prevent damage and fuel spillage.

Never operate the PowerBroom around objects that could tangle in the drums and cause loss of control.

Never allow the engine to run at high RPM without a load. Doing so could damage the engine.

Be constantly alert for objects and debris that could be thrown either from the sweeper belts or bounced from a hard surface.

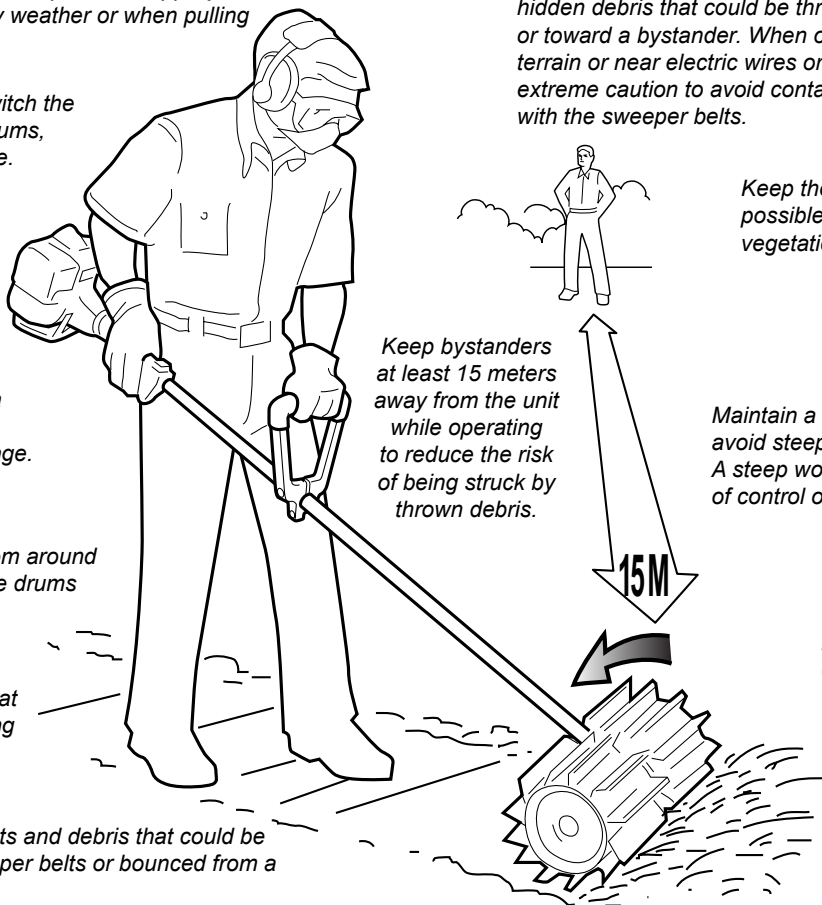

ALWAYS clear your work area of trash or hidden debris that could be thrown back at you or toward a bystander. When operating in rocky terrain or near electric wires or fences, use extreme caution to avoid contacting such items with the sweeper belts.

Keep the unit as clean as possible. Keep it free of loose vegetation, mud, etc.

Keep bystanders at least 15 meters away from the unit while operating to reduce the risk of being struck by thrown debris.

Maintain a low working angle and avoid steep angles of operation. A steep working angle risks loss of control of the machine.

Transport the machine with the engine OFF.

Always keep the handles clean.

## Product Description

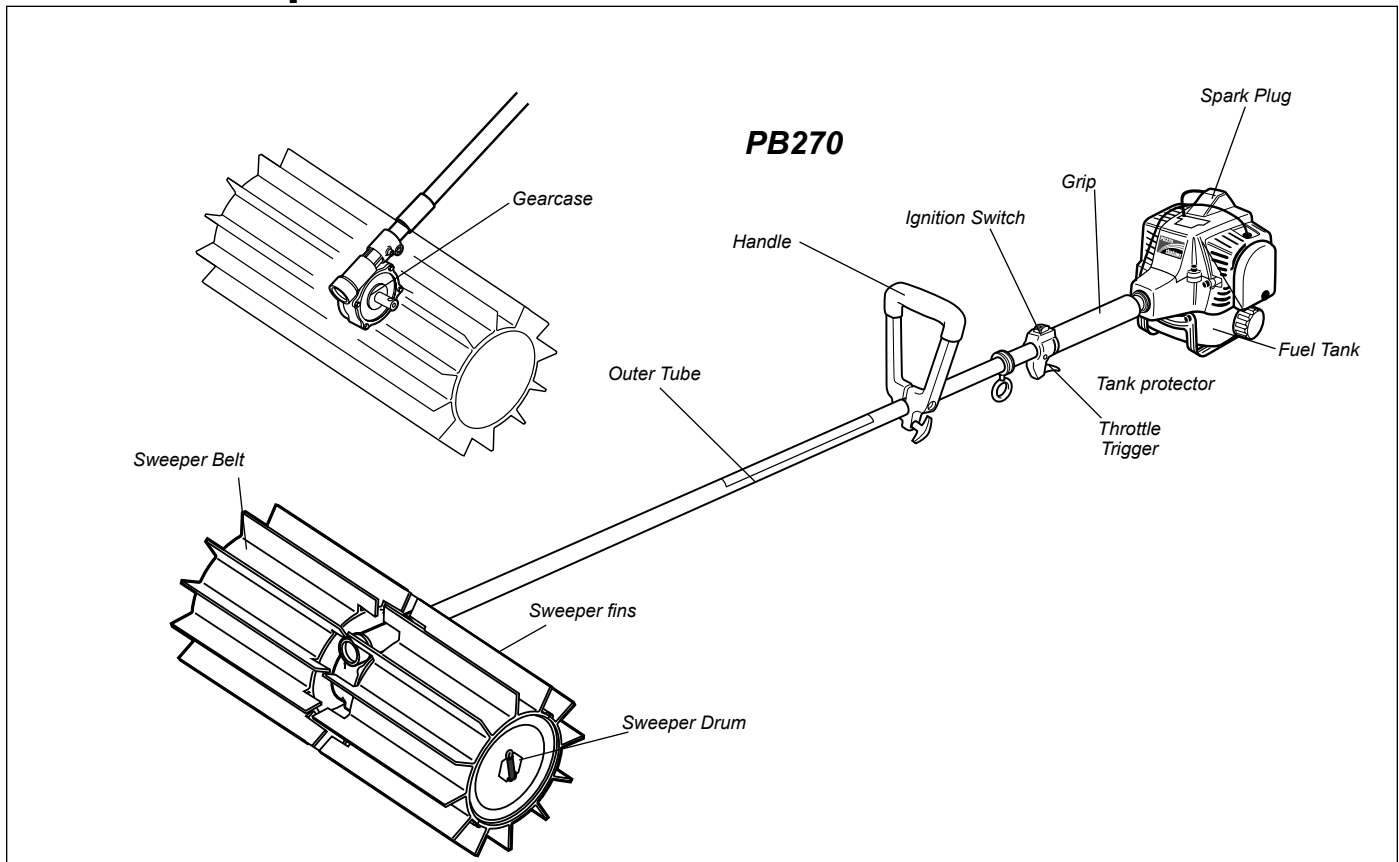

Using the illustration as a guide, familiarize yourself with your machine and its various components. Understanding your machine helps ensure top performance, long service life and safer operation.



### WARNING!

Do not make unauthorized modifications or alterations to any of these units or their components.

### IMPORTANT!

The terms “left”, “left-hand”, and “LH”; “right”, “right-hand”, and “RH”; “front” and “rear” refer to directions as viewed by the operator during normal operation.

## Specifications

Engine Model	S270
Engine Type	2-cycle, vertical-cylinder, air-cooled
Dry Weight (less sweepers)	5.2 kg/11.5 lb.
Dry Weight (Including sweepers)	9.8 kg/21.5 lb.
Bore x Stroke	34 x 30 mm/1.34 x 1.18 in.
Displacement	27.2 cc/1.7 cu. in.
Maximum Power Output	1.5 HP (1.1 kW) @ 7500 min <sup>-1</sup>
Fuel/Oil Ratio	50:1 with Shindaiwa Premium 2-cycle mixing oil
Fuel Tank Capacity	660 ml/22.3 oz..
Carburetor Type	TK, diaphragm-type
Ignition	One-piece electronic, transistor controlled
Spark Plug	Champion CJ8Y / NGK BPMR7A
Air Cleaner Type	Foam element
Starting Method	Recoil
Stopping Method	Slide switch
Transmission Type	Automatic, centrifugal clutch w/worm gear
EPA Emission Compliance Period*	Category A

\*Specifications are subject to change without notice.

\*The EPA emission compliance period referred to on the emission compliance label located on the engine, indicates the number of operating hours for which the engine has been shown to meet Federal emission requirements. Category C = 50 hours (Moderate), B = 125 hours (Intermediate) and A = 300 hours (Extended)

## Assembly

### Prior to assembly

Before assembling, make sure you have all the components required for a complete unit:

- Engine assembly
- Outer tube assembly
- Drum kit with gearcase

- Kit containing operator's handle, hardware, owner/operator's manual, tool kit for routine maintenance. Tool kits vary by model and may include a hex wrench, spanner, and a combination spark plug wrench/screwdriver.
- Carefully inspect all components for damage before assembling.

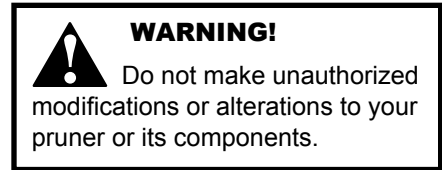

### Connect the Outer Tube to the Powerhead

1. Place the powerhead on a clean, flat surface, spark plug facing up.
2. Use the 4mm hex wrench to loosen the index screw and tube clamp screw. Verify that the D-shaped shim washer is positioned as shown
5. Position the outer tube so that the ignition switch is facing up and the throttle trigger is down.
6. Slide the outer tube into the powerhead until the throttle grip just contacts the tube clamp.

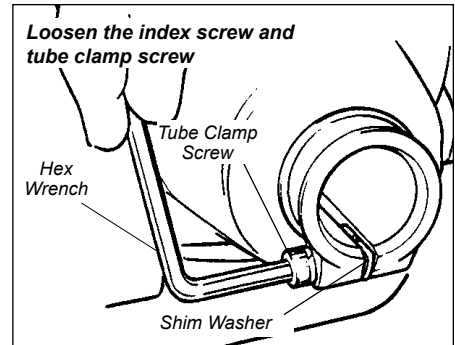

#### CAUTION!

Do not remove the D-shaped shim washer! The shim washer prevents damage from overtightening the tube clamp screw.

#### CAUTION!

Do not force the shaft tube into the powerhead! Excessive force can damage the shaft tube and

3. Add some moly-type EP grease to the splines on the end of the mainshaft.
4. Slide the outer tube into the tube clamp until the tube bottoms. If installation is difficult, rotate the outer tube or mainshaft slightly until you feel the mainshaft splines engage with the powerhead.

7. Tighten the clamp screw firmly.

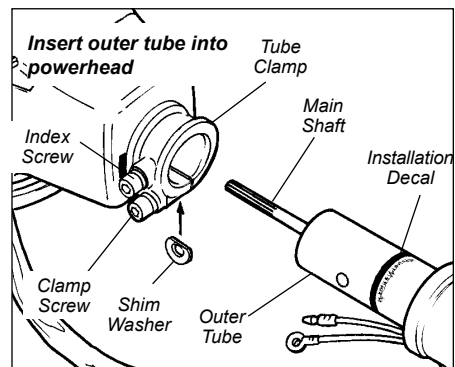

### Throttle Cable and Ignition Leads

1. Unscrew the two throttle lever cover screws, and then separate the throttle control halves as shown.
2. Working from the powerhead, push the throttle cable through the passageway in the base of the shaft tube grip.
3. Insert the throttle cable end into the molded receptacle in the throttle lever, and then lay the cable wire in the molded slot in the throttle body.
4. In the reverse order of removal, reassemble the throttle body and cover on the shaft tube.
5. Plug the red ignition lead from the shaft tube into the red lead from the powerhead, and then connect the black grounding wire to the powerhead.

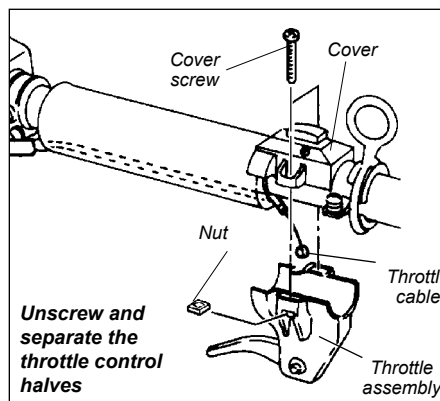

#### CAUTION!

Overtightening the throttle assembly screws can permanently damage the plastic throttle components!

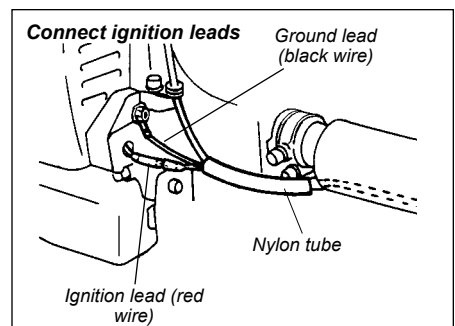
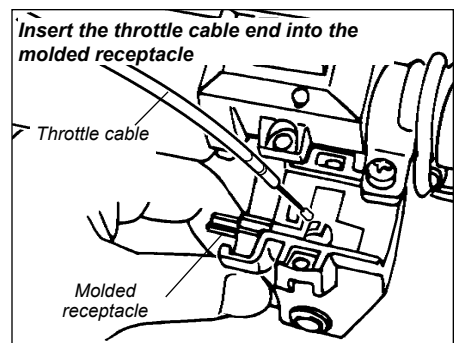

## Assembly (continued)

### Adjustable Handle Installation

Follow these instructions if you wish to use the PowerBroom's adjustable handle instead of the loop handle on your powerhead assembly. Remove the powerhead assembly's loop handle.

1. Remove both screws from the PowerBroom's adjustable handle assembly.
2. While spreading the handle at the mounting hole, position the handle on the outer tube as shown.
3. Reinstall the two mounting screws in the handle, but do not tighten them at this time.
4. Locate the handle at the best position for operator comfort (usually about 10 inches ahead of the throttle lever), and secure it by tightening the adjustment knob at the handle base.

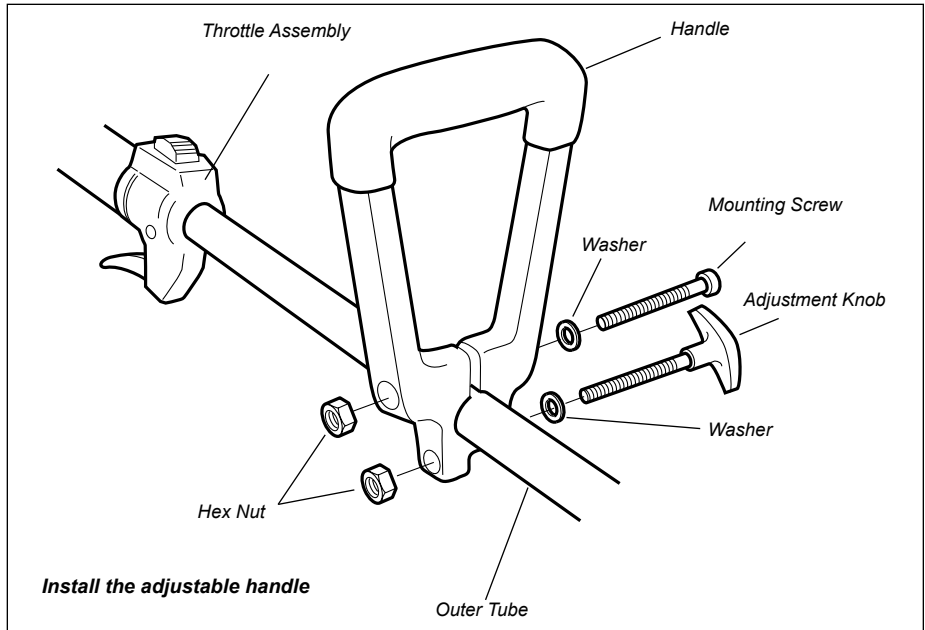

### IMPORTANT!

One side of the handle is recessed to receive the two hex nuts.

### Throttle lever free play

1. Test the throttle lever for smooth operation. If any stiffness or binding are noted, repeat Steps 1 through 4 (on the previous page).
2. Test the throttle lever for proper "free play" of approximately 7mm in the idle position. If necessary, adjustments can be made at the carburetor by loosening the cable locknut and then raising or lowering the cable adjuster as required.

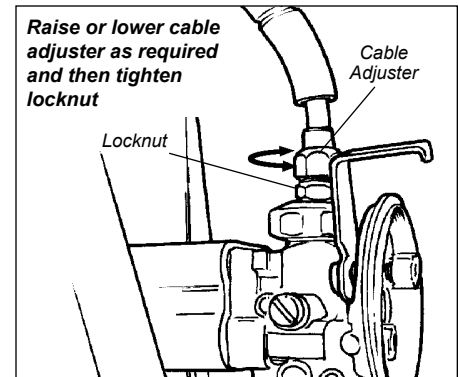
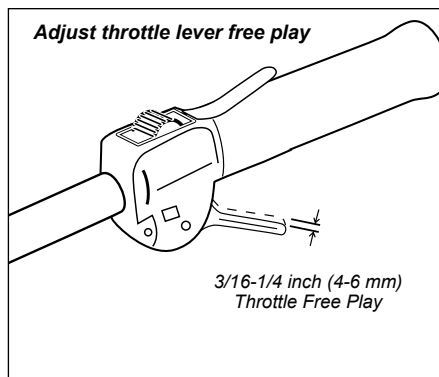

## Assembly (continued) Sweeper Assembly

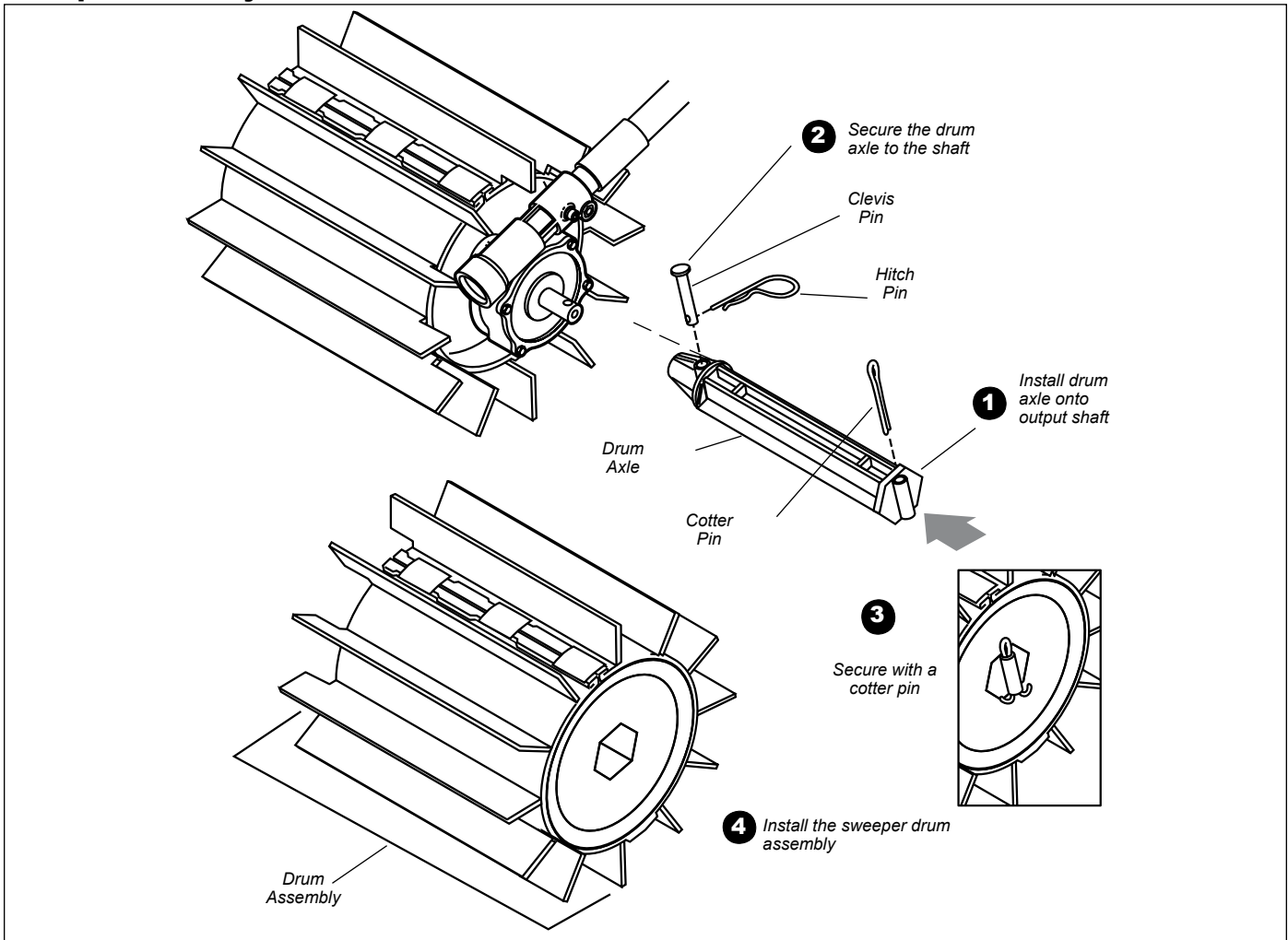

1. Push one of the drum axles onto either of the two gearcase output shafts. If necessary, rotate the drum axle until the clevis pin hole in the axle aligns with the matching hole in the gearcase output shaft.

### CAUTION!

The two drum assemblies are identical, but each drum must be installed with its recessed end facing toward the gearcase.

2. Use a clevis pin and hitch pin to secure the drum axle to the shaft.
3. Slide the recessed end of a sweeper drum assembly over the installed axle, and then push the drum down the axle until the cotter pin hole in the axle extends above the drum surface.
4. Use a cotter pin to secure the drum assembly on the axle (see inset). The cotter pin is designed to fit tightly against the outboard end of the drum, so you may need to compress the drum face slightly during installation. spread the ends of the cotter pin to secure.

5. Repeat Steps 1-4 to install the remaining axle and drum assembly.

**The PowerBroom tool should now be completely assembled.**



## Mixing Fuel



### WARNING!

Alternative fuels, such as E15 (15% ethanol), E-85 (85% ethanol) or any fuels not meeting Shindaiwa requirements are **NOT** approved for use in Shindaiwa gasoline engines. Use of alternative fuels may cause performance problems, loss of power, overheating, fuel vapor lock, and unintended machine operation, including, but not limited to, improper clutch engagement. Alternative fuels may also cause premature deterioration of fuel lines, gaskets, carburetors and other engine components.

### Fuel Requirements

**Gasoline** - Use 89 Octane [R+M/2] (mid grade or higher) gasoline known to be good quality. Gasoline may contain up to 10% Ethanol (grain alcohol) or 15% MTBE (methyl tertiary-butyl ether). Gasoline containing methanol (wood alcohol) is **NOT** approved.

**Hybrid 4™ Mixture Oil** - Engine oil meeting ISO-L-EGD (ISO/CD 13738) and J.A.S.O. M345/FD standards must be used. Shindaiwa highly recommends using Shindaiwa Red Armor™ engine oil in all Shindaiwa Hybrid 4™ engines to protect the engine from harmful carbon build up, maintain engine performance, and increase engine life. Shindaiwa Red Armor™ engine oil exceeds ISO-L-EGD and J.A.S.O. M345/FD performance requirements. Engine problems due to inadequate lubrication caused by failure to use an ISO-L-EGD (ISO/CD 13738) and J.A.S.O. M345/FD certified oil will void the engine warranty.

### IMPORTANT!

Shindaiwa Red Armor™ engine oil may be mixed at 50:1 ratio for application in all Shindaiwa engines sold in the past, regardless of ratio specified in those manuals.

### IMPORTANT!

Stored fuel ages. Do not mix more fuel than you expect to use in thirty (30) days, ninety (90) days when a fuel stabilizer is added. Use of unmixed, improperly mixed, or stale fuel, may cause hard starting, poor performance, or severe engine damage and void the product warranty. Read and follow instructions in the Long Term Storage section of this manual.

### Examples of 50:1 mixing quantities

Fuel to Oil Mix - 50:1 Ratio			
U.S.		METRIC	
GAS	OIL	GAS	OIL
Gallons	Fl. oz.	Liter	cc.
1	2.6	4	80
2	5.2	8	160
5	13	20	400

## Handling Fuel



### DANGER

Fuel is **VERY** flammable. Use extreme care when mixing, storing or handling or serious personal injury may result.

- Use an approved fuel container.
- DO NOT smoke near fuel.
- DO NOT allow flames or sparks near fuel.
- Fuel tanks/cans may be under pressure. Always loosen fuel caps slowly allowing pressure to equalize.
- NEVER refuel a unit when the engine is HOT or RUNNING!
- DO NOT fill fuel tanks indoors. ALWAYS fill fuel tanks outdoors over bare ground.
- DO NOT overfill fuel tank. Wipe up spills immediately.
- Securely tighten fuel tank cap and close fuel container after refueling.
- Inspect for fuel leakage. If fuel leakage is found, do not start or operate unit until leakage is repaired.
- Move at least 3m (10 ft.) from refueling location before starting the engine.

### Mixing Instructions

1. Fill an approved fuel container with half of the required amount of gasoline.
2. Add the proper amount of engine oil to gasoline.
3. Close container and shake to mix oil with gasoline.
4. Add remaining gasoline, close fuel container, and remix.

#### IMPORTANT!

Spilled fuel is a leading cause of hydrocarbon emissions. Some states may require the use of automatic fuel shut-off containers to reduce fuel spillage.

#### After use

- DO NOT store a unit with fuel in its tank. Leaks can occur. Return unused fuel to an approved fuel storage container.

**Storage** - Fuel storage laws vary by locality. Contact your local government for the laws affecting your area. As a precaution, store fuel in an approved, airtight container. Store in a well-ventilated, unoccupied building, away from sparks and flames.

#### IMPORTANT!

Stored fuel may separate. ALWAYS shake fuel container thoroughly before each use.

## Filling the fuel tank



### WARNING!

#### Minimize the Risk of Fire

- NEVER smoke or light fires near the engine.
- ALWAYS stop the engine and allow it to cool before refueling.
- ALWAYS Wipe all spilled fuel and move at least 3 meters (10 feet) from the fueling point and source before starting.
- NEVER place flammable material close to the engine muffler.
- NEVER operate the engine without the muffler and spark arrester screen in place and in good working condition.
- FUEL IS HIGHLY FLAMMABLE.
- ALWAYS store gasoline in a container approved for flammable liquids.
- ALWAYS inspect the unit for fuel leaks before each use. During each refill, check that no fuel leaks from around the fuel cap and/or fuel tank. If fuel leaks are evident, stop using the unit immediately. Fuel leaks must be repaired before using the unit.
- ALWAYS move the unit at least 3 meters (10 feet) away from a fuel storage area or other readily flammable materials before starting the engine.

1. Place the unit on a flat, level surface.
2. Clear any dirt or other debris from around the fuel filler cap.

### CAUTION!

Slowly remove the fuel cap only after stopping the engine

3. Remove the fuel cap, and fill the tank with clean, fresh fuel.
4. Reinstall the fuel filler cap and tighten firmly.
5. Wipe away any spilled fuel before starting engine.

# Starting the Engine

## IMPORTANT!!

Engine ignition is controlled by a two position switch mounted on the throttle housing labeled, “I” for ON or START and “O” for OFF or STOP.



### WARNING!

Never start the engine from the operating position.

1. Slide the ignition switch to the “ON” position.
2. Set the throttle lever to the “fast idle”:
  - a. Squeeze the throttle lever toward the handgrip on the shaft tube.
  - b. Depress and hold the throttle lock button.
  - c. While depressing the throttle lock button, release the throttle lever.
3. Press the primer bulb until fuel can be seen flowing in the transparent return tube.
4. Set the choke lever to the CLOSED position if engine is cold.

### IMPORTANT!

The primer system only pushes fuel through the carburetor. Repeatedly pressing the primer bulb will not flood the engine with fuel.

5. While holding the outer tube firmly with left hand. Use your other hand to slowly pull the recoil starter handle until resistance is felt, then pull quickly to start the engine.

### CAUTION!

Do not pull the recoil starter to the end of the rope travel. Pulling the recoil starter to the end of the rope travel can damage the starter.

### When the Engine Starts...

- After the engine starts, open the choke (if it is not already open) by moving the choke lever down. Allow the engine to warm up at idle 2 or 3 minutes before operating the unit.
- Advancing the throttle makes the cutting attachment turn faster; releasing the throttle permits the attachment to stop turning.

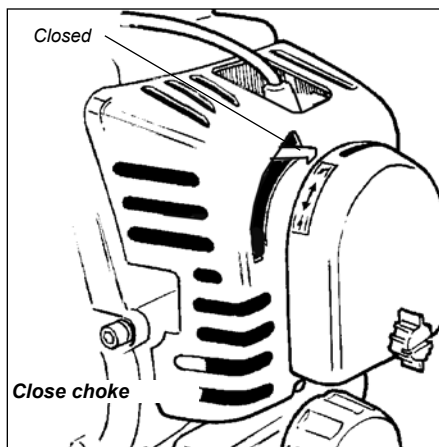
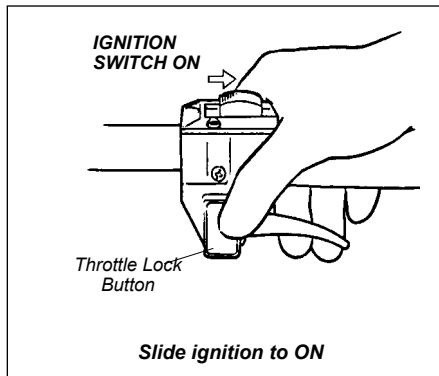

### WARNING!

The PowerBroom attachment may rotate when the engine is started!

6. When the engine starts, slowly move the choke lever to the “OPEN” position. (If the engine stops after the initial start, close the choke and restart.)
7. Operating the throttle will automatically disengage the fast idle setting.

- If the cutting attachment continues to rotate when the engine returns to idle, carburetor idle speed should be adjusted (see “Adjusting Engine Idle” below).

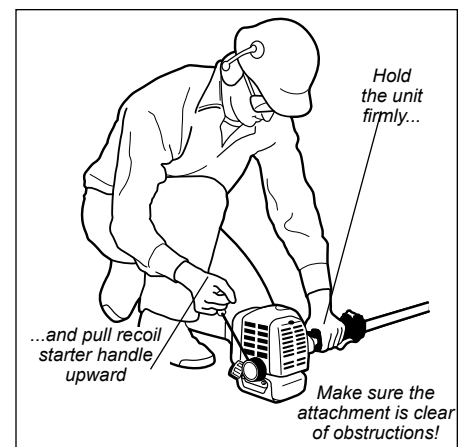
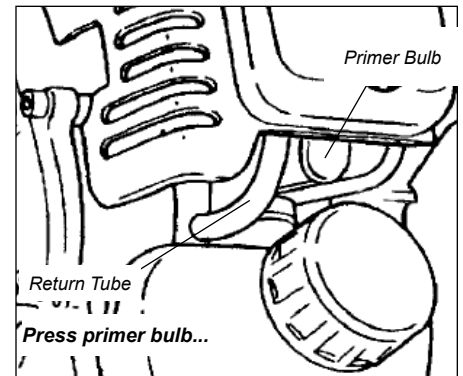

### IMPORTANT!

If the engine fails to start after several attempts with the choke in the closed position, the engine may be flooded with fuel. If flooding is suspected, move the choke lever to the open position and repeatedly pull the recoil starter to remove excess fuel and start the engine. If the engine still fails to start, refer to the troubleshooting section of this manual.

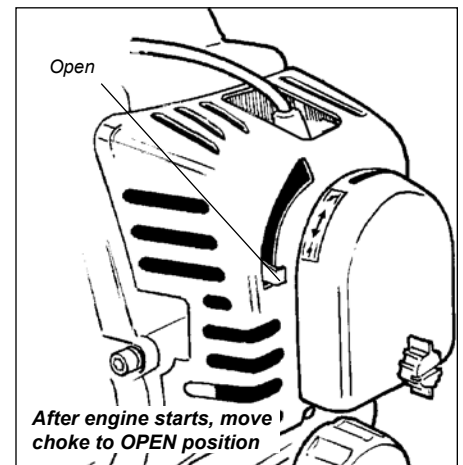

## Stopping the Engine

Idle the engine briefly before stopping (about 2 minutes), then slide the ignition switch to the "O" (Engine OFF) position.

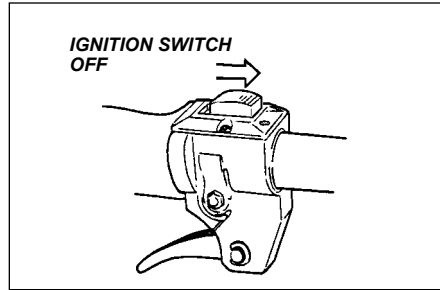

## Adjusting Engine Idle

The engine must return to idle speed whenever the throttle lever is released. Idle speed is adjustable, and must be set low enough to permit the engine clutch to disengage the cutting attachment.



### WARNING!

The cutting attachment must NEVER rotate at engine idle! If the idle speed cannot be adjusted by the procedure described here, return the trimmer to your Shindaiwa dealer for inspection.

### Idle Speed Adjustment

1. Place the trimmer on the ground, then start the engine, and then allow it to idle 2-3 minutes until warm.
2. If the attachment rotates when the engine is at idle, reduce the idle speed by turning the idle adjustment screw counter-clockwise.
3. If a tachometer is available, the engine idle speed should be final adjusted to 3,000 ( $\pm 300$ ) rpm ( $\text{min}^{-1}$ ).
4. Carburetor fuel mixture adjustments are preset at factory and cannot be serviced in the field.

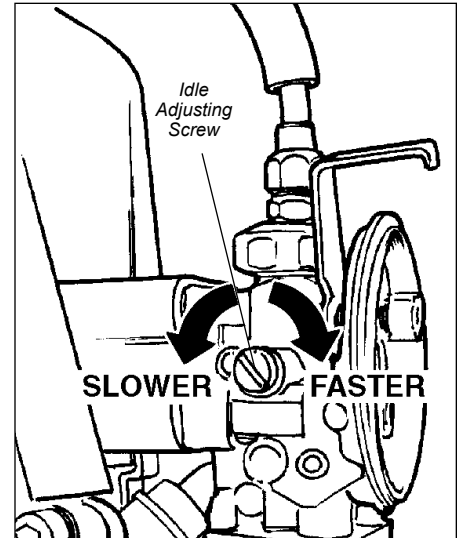

## Checking Unit Condition

**NEVER** operate the unit with the protective devices (ignition switch, etc.) removed!

**ALWAYS** make sure the PowerBroom tool is properly installed and firmly tightened before operation.

Use only authorized Shindaiwa parts and accessories with your Shindaiwa Multipurpose Tool. Do not make modifications to your machine without the written approval of Shindaiwa.

**NEVER** use a cracked or warped PowerBroom drum or axle; replace it with a serviceable one.

**ALWAYS** stop the engine immediately and check for damage if you strike a foreign object or if the machine becomes tangled. Do not operate with broken or damaged equipment.

**NEVER** allow the engine to run at high RPM without a load. Doing so could damage the engine.

**NEVER** operate a machine with worn or damaged fasteners or attachment holders.

## Operating Break-in and Operation

The PowerBroom works best when its rubber fins can quickly slide or “skim” over the surface being swept. New or replacement sweeper belts tend to grip or drag on hard surfaces, and should be thoroughly broken in or “scuffed” before the broom is actually put to work.

Break-in is easily accomplished by operating the PowerBroom at full throttle for 3 to 5 minutes in loose gravel or similar abrasive material.

## Optional accessories

### Debris shield p/n 99909-33021

A plastic debris shield is available from your Shindaiwa dealer as a useful option to your PowerBroom. The shield helps prevent broadcasting debris when large volumes of material are forced over the top of the drum during operation.

Once broken in, a PowerBroom will effortlessly move an amazing variety of materials, ranging from snow or standing water to heavier objects such as gravel or wood chips.

Experience will help you understand the operating principles of the PowerBroom, but safe operation must be practiced from the start.

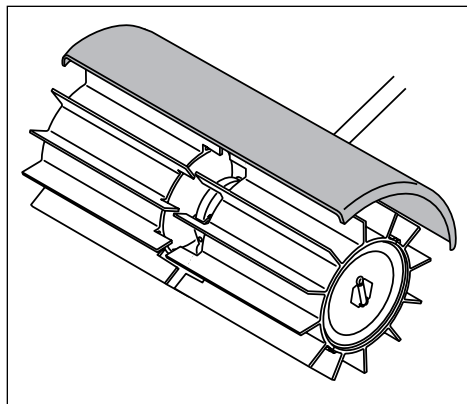

## Operating Techniques

Operate the PowerBroom at or near full throttle with its sweeper fins resting on the work surface.

### IMPORTANT!

It is both tiring and unnecessary to lift or hold the fins from the work surface during sweeping.

When sweeping narrow areas such as sidewalks, the PowerBroom can be used to throw material directly ahead of the operator. Clearing wider areas may require sweeping at an angle to create windrows to one side of the path being cleared.

Windrows of lighter materials often can be combined into one main row or pile for eventual pickup, while heavy or bulky material may need to be collected row-by-row.

To pull debris from corners, reverse sweeper drum rotation by turning the powerhead over (throttle facing “up”).

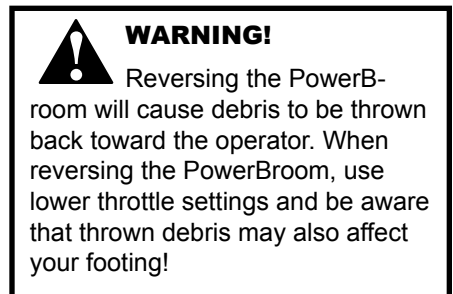
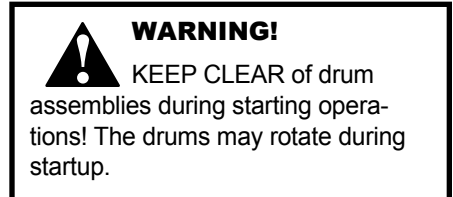
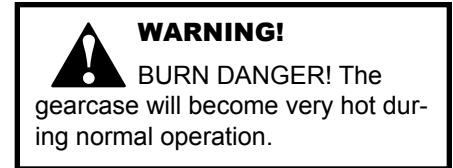
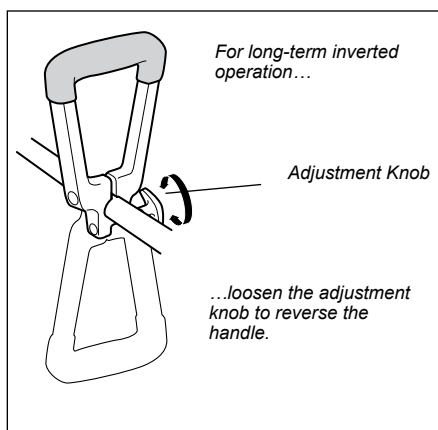
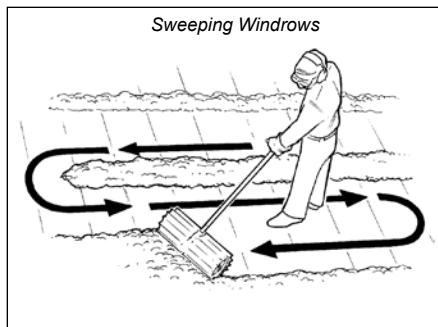

## Maintenance

### IMPORTANT!

MAINTENANCE, REPLACEMENT OR REPAIR OF EMISSION CONTROL DEVICES AND SYSTEMS MAY BE PERFORMED BY ANY REPAIR ESTABLISHMENT OR INDIVIDUAL; HOWEVER, WARRANTY REPAIRS MUST BE PERFORMED BY A DEALER OR SERVICE CENTER AUTHORIZED BY ECHO, INC. THE USE OF PARTS THAT ARE NOT EQUIVALENT IN PERFORMANCE AND DURABILITY TO AUTHORIZED PARTS MAY IMPAIR THE EFFECTIVENESS OF THE EMISSION CONTROL SYSTEM AND MAY HAVE A BEARING ON THE OUTCOME OF A WARRANTY CLAIM.

### Daily Maintenance

Prior to each work day, perform the following:

- Remove all dirt and debris from the engine, check the cooling fins and air cleaner for clogging, and clean as necessary.
- Check the entire unit for leaking fuel or grease.

### 10-Hour Maintenance

Every 10 hours of operation (more frequently in dusty or dirty conditions):

Remove the air cleaner element from the carburetor and clean it thoroughly with soap and water or compressed air, let dry before reinstalling the element.

### IMPORTANT!

Direct the air stream at the inside face of the filter only!

### CAUTION!

Never operate the unit if the air cleaner assembly is damaged or missing!

### Muffler

This unit must never be operated with a faulty or missing spark arrester or muffler. Make sure the muffler is well secured and in good condition. A worn or damaged muffler is a fire hazard and may also cause hearing loss.

### Spark Plug

Keep the spark plug and wire connections tight and clean.

### Fasteners

Make sure nuts, bolts, and screws (except carburetor adjusting screws) are tight.



### WARNING!

Before performing any maintenance, repair, or cleaning work on the unit, make sure the engine and cutting attachment are completely stopped. Disconnect the spark plug wire before performing service or maintenance.



### WARNING!

Non-standard accessories, cutting attachment, or replacement parts may not operate properly with your unit and may cause damage and lead to personal injury.

- Carefully remove any accumulations of dirt or debris from the muffler and fuel tank. Check cooling air intake area at base of crankcase. Remove all debris. Dirt build-up in these areas can lead to engine overheating, fire, or premature wear.
- Clean any debris or dirt from the sweeper attachment.
- Check for loose or missing screws or components. Make sure the cutter attachment is securely fastened.
- Make sure nuts, bolts, and screws (except carburetor idle speed adjusting screws) are tight.

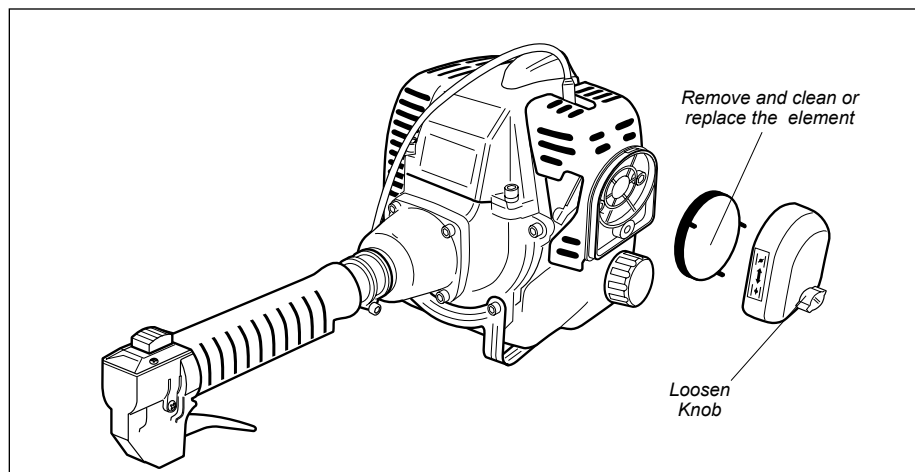

## Maintenance (continued)

### 10/15-Hour Maintenance

Remove and clean or replace the spark plug.

- Adjust the spark plug electrode gap to 0.024–0.028 inch (0.6–0.7 mm). If the spark plug must be replaced, use only an Champion CJ8Y or NGK BPMR7A, or equivalent resistor type spark plug of the correct heat range.

#### CAUTION!

Before removing the spark plug, clean the area around the plug to prevent dirt and debris from getting into the engine's internal parts.

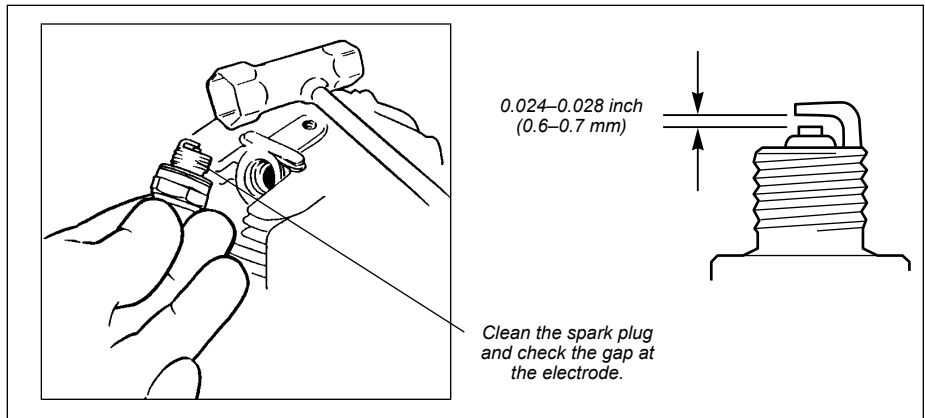

### 50 hour maintenance

(more frequently in dusty or dirty conditions)

- Remove and clean the cylinder cover and clean grass and dirt from the cylinder fins.

Remove and replace the fuel filter element.

- Use a hooked wire to remove the fuel filter element.

Before reinstalling the new filter element, inspect the condition of all the fuel system components (fuel pick-up line, fuel return line, tank vent line, tank vent, fuel cap and fuel tank).

If damage, splitting or deterioration is noted, the unit should be removed from service until it can be inspected or repaired by a Shindaiwa-trained service technician.

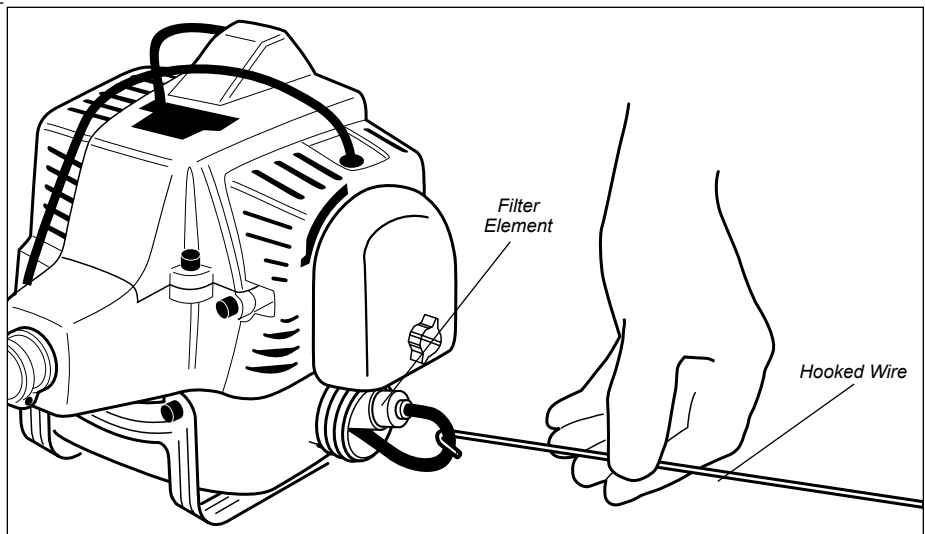

#### CAUTION!

Make sure you do not pierce the fuel line with the end of the hooked wire, the line is delicate and can be damaged easily.

## Maintenance (continued)

### 300-hour maintenance

#### Gearcase Lubrication

The gearcase should be filled with 60 cc (2.0 fl.oz.) of Mobil SHC634 Synthetic Gear Oil. A maximum of 75-80 cc can be used, but never to exceed 80 cc. Operation with excessive oil level will result in high operating temperatures. **Do not overfill!**



#### **WARNING!**

**BURN DANGER!** The gearcase will be extremely hot after use!

#### Replacing the gearcase oil

1. Disconnect spark plug wire at engine.
2. Remove the LH Drum and axle assembly (as viewed from the operating position). Wipe the sideplate clean and remove four screws (it is not necessary to remove the gearcase from the outer tube).
3. Turn gearcase side plate to break the seal and lift the plate from the gearcase.

#### **NOTE:**

It may be necessary to use a heat gun to soften the sealer material.

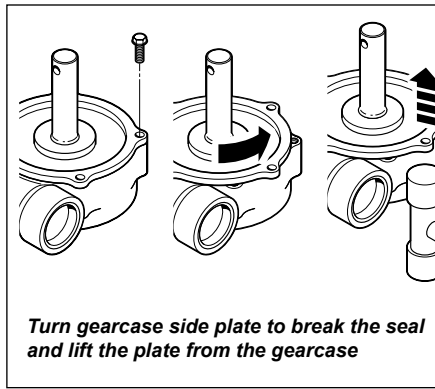

*Turn gearcase side plate to break the seal and lift the plate from the gearcase*

4. Turn the gearcase to the LH side and allow all used gearcase oil to drain into a small container.
5. Place the gearcase on the RH side and supported so the outer tube is parallel to the ground. Refill the gearcase with 60 cc (2.0 fl.oz) of Mobil SHC634 Synthetic Gear Oil to the bottom of the chamfer on the output gear. The correct oil depth is 5/8" (15.5 mm). **DO NOT OVERFILL!**

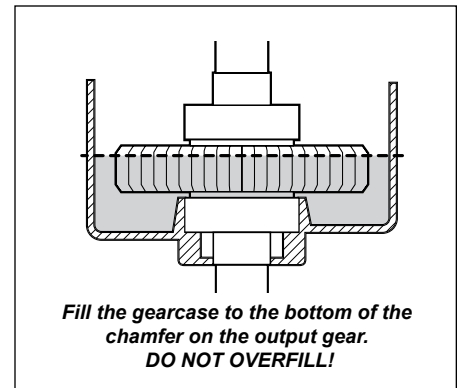

*Fill the gearcase to the bottom of the chamfer on the output gear. **DO NOT OVERFILL!***

6. Inspect the sideplate for damage and clean off all remaining liquid gasket material with brake cleaner or acetone. Coat the outer sealing flange of the sideplate with Loctite Ultragrey Silicon Sealant or Threebond No. 1104 Liquid Gasket.
7. Replace the cover and install the four sideplate screws. Tighten securely.
8. Reinstall the drum and axle assembly. Refer to the section "Assembly: Sweeper Assembly" for instructions.



## Maintenance (continued)

### Muffler Maintenance



#### WARNING!

Never operate the unit with a damage or missing muffler or spark arrester! Operating with a missing or damaged spark arrester is a fire hazard and could also damage your hearing.

Hard starting or a gradual loss of performance can be caused by carbon deposits lodged in the muffler's spark arrester screen.

In such cases, performance can usually be restored by removing the spark arrester screen and giving it a thorough cleaning with a stiff bristle brush.

If carbon deposits are severe or if no performance improvement is noted, your unit should be returned to your Shindaiwa dealer for inspection.

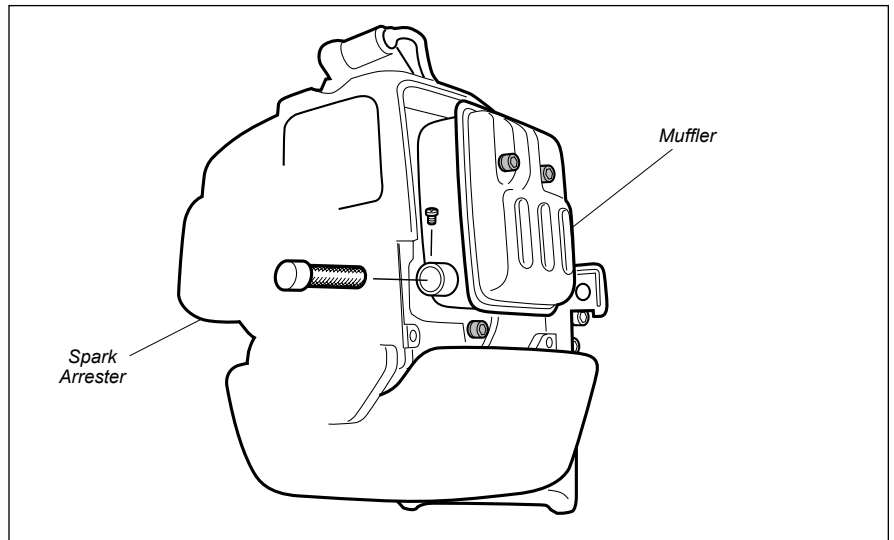

## Long Term Storage

Whenever the unit will not be used for 30 days or longer, use the following procedures to prepare it for storage:

- Clean external parts thoroughly and apply a light coating of oil to all metal surfaces.
- Drain all the fuel from the carburetor and the fuel tank.

To do so:

1. Prime the primer bulb until no more fuel is passing through.
2. Start and run the engine until it stops running.
3. Repeat steps 1 and 2 until the engine will no longer start.

#### CAUTION!

Gasoline stored in the carburetor for extended periods can cause hard starting, and could also lead to increased service and maintenance costs.

#### IMPORTANT!

All stored fuels should be stabilized with a fuel stabilizer such as STA-BIL™.

#### NOTE

Damage resulting from stale or contaminated fuel is not covered by the Shindaiwa warranty policy.

- Remove the spark plug and pour about 1/4 oz. of engine oil into the cylinder through the spark plug hole. Slowly pull the recoil starter 2 or 3 times so oil will evenly coat the interior of the engine. Reinstall the spark plug.
- Before storing the unit, repair or replace any worn or damaged parts.
- Remove the air cleaner element from the carburetor and clean it thoroughly with soap and water. Let dry and reassemble the element.
- Store the unit in a clean, dust-free area.

# Troubleshooting Guide

## ENGINE DOES NOT START OR HARD TO START

What To Check	Possible Cause	Remedy
Vaporlock.	<ul style="list-style-type: none"> <li>Engine hot/heat soaked.</li> <li>Low fuel quality.</li> </ul>	<ul style="list-style-type: none"> <li>Let cool completely and restart.</li> <li>Refill with fresh, clean unleaded gasoline with a pump octane of 89 or higher mixed with an air cooled engine oil that meets or exceeds ISO-L-EGD and/or JASO FD classified oils at 50:1 gasoline/oil ratio.</li> </ul>

## ENGINE DOES NOT START

What To Check	Possible Cause	Remedy
<p>Does the engine crank?</p> <p>NO</p> <p>YES</p>	<ul style="list-style-type: none"> <li>Faulty recoil starter.</li> <li>Fluid in the crankcase.</li> <li>Internal damage.</li> </ul>	<ul style="list-style-type: none"> <li>Consult with an authorized Shindaiwa servicing dealer.</li> </ul>
<p>Good compression?</p> <p>NO</p> <p>YES</p>	<ul style="list-style-type: none"> <li>Loose spark plug.</li> <li>Excess wear on cylinder, piston, rings.</li> </ul>	<ul style="list-style-type: none"> <li>Tighten and re-test.</li> <li>Consult with an authorized Shindaiwa servicing dealer.</li> </ul>
<p>Does the tank contain fresh fuel of the proper grade?</p> <p>NO</p> <p>YES</p>	<ul style="list-style-type: none"> <li>Fuel incorrect, stale, or contaminated; mixture incorrect.</li> </ul>	<ul style="list-style-type: none"> <li>Refill with fresh, clean unleaded gasoline with a pump octane of 89 or higher mixed with an air cooled engine oil that meets or exceeds ISO-L-EGD and/or JASO FD classified oils at 50:1 gasoline/oil ratio.</li> </ul>
<p>Is fuel visible and moving in the return line when priming?</p> <p>NO</p> <p>YES</p>	<ul style="list-style-type: none"> <li>Check for clogged fuel filter and/or vent.</li> <li>Priming pump not functioning properly.</li> </ul>	<ul style="list-style-type: none"> <li>Replace fuel filter or vent as required. Re-start.</li> <li>Consult with an authorized Shindaiwa servicing dealer.</li> </ul>
<p>Is there spark at the spark plug wire terminal?</p> <p>NO</p> <p>YES</p>	<ul style="list-style-type: none"> <li>The ignition switch is in "O" (OFF) position.</li> <li>Shorted ignition ground.</li> <li>Faulty ignition unit.</li> </ul>	<ul style="list-style-type: none"> <li>Move switch to "I" (ON) position and re-start.</li> <li>Consult with an authorized Shindaiwa servicing dealer.</li> </ul>
<p>Check the spark plug.</p>	<ul style="list-style-type: none"> <li>If the plug is wet, excess fuel may be in the cylinder.</li> <li>The plug is fouled or improperly gapped.</li> <li>The plug is damaged internally or of the wrong size.</li> </ul>	<ul style="list-style-type: none"> <li>See "Starting a Flooded Engine"</li> <li>Clean and gap the spark plug. Check the Specifications section for the correct plug and gap for your unit. Restart.</li> <li>Replace the spark plug. Check the Specifications section for the correct plug and gap for your unit. Restart.</li> </ul>

# Troubleshooting Guide (continued)

## LOW POWER OUTPUT

What To Check	Possible Cause	Remedy
<p><b>Is the engine overheating?</b></p>	Operator is over working the unit.	Use a lower throttle setting.
	Carburetor mixture is too lean.	Consult with an authorized Shindaiwa servicing dealer.
	Improper fuel ratio.	Refill with fresh, clean unleaded gasoline with a pump octane of 89 or higher mixed with an air cooled engine oil that meets or exceeds ISO-L-EGD and/or JASO FD classified oils at 50:1 gasoline/oil ratio.
	Fan, fan cover, cylinder fins dirty or damaged.	Clean, repair or replace as necessary.
	Carbon deposits on the piston or in the muffler.	Consult with an authorized Shindaiwa servicing dealer.
<p><b>Engine is rough at all speeds. May also have black smoke and/or unburned fuel at the exhaust.</b></p>	Clogged air cleaner element.	Service the air cleaner element.
	Loose or damaged spark plug.	Tighten or replace the spark plug. Check the <i>Specifications</i> section for the correct plug and gap for your unit.
	Air leakage or clogged fuel line.	Repair or replace fuel filter and/or fuel line.
	Water in the fuel.	Refill with fresh, clean unleaded gasoline with a pump octane of 89 or higher mixed with an air cooled engine oil that meets or exceeds ISO-L-EGD and/or JASO FD classified oils at 50:1 gasoline/oil ratio.
	Piston seizure.	Consult with an authorized Shindaiwa servicing dealer.
	Faulty carburetor and/or diaphragm.	
<p><b>Engine is knocking.</b></p>	Overheating condition.	Consult with an authorized Shindaiwa servicing dealer.
	Improper fuel.	Refill with fresh, clean unleaded gasoline with a pump octane of 89 or higher mixed with an air cooled engine oil that meets or exceeds ISO-L-EGD and/or JASO FD classified oils at 50:1 gasoline/oil ratio.
	Carbon deposits in the combustion chamber.	Consult with an authorized Shindaiwa servicing dealer.

# Troubleshooting Guide (continued)

## ADDITIONAL PROBLEMS

Symptom	Possible Cause	Remedy
<b>Poor acceleration.</b>	Clogged air filter.	Clean the air filter.
	Clogged fuel filter.	Replace the fuel filter.
	Lean fuel/air mixture.	Consult with an authorized Shindaiwa servicing dealer.
	Idle speed set too low.	Adjust idle. Check <i>Specifications</i> page for correct idle speed.
<b>Engine stops abruptly.</b>	Ignition switch turned off.	Reset the switch and re-start.
	Fuel tank empty.	Refill with fresh, clean unleaded gasoline with a pump octane of 89 or higher mixed with an air cooled engine oil that meets or exceeds ISO-LEGD and/or JASO FD classified oils at 50:1 gasoline/oil ratio.
	Water in the fuel.	
	Clogged fuel filter.	Replace fuel filter.
	Shorted spark plug or loose terminal.	Clean or replace spark plug. Check the <i>Specifications</i> section for the correct plug and gap for your unit. Tighten the terminal.
	Ignition failure.	Replace the ignition unit.
	Piston seizure.	Consult with an authorized Shindaiwa servicing dealer.
<b>Engine difficult to shut off.</b>	Ground (stop) wire is disconnected, or switch is defective.	Test and replace as required.
	Overheating due to incorrect spark plug.	Replace the spark plug. Check the <i>Specifications</i> section for the correct plug and gap for your unit. Restart.
	Overheated engine.	Idle engine until cool.
<b>Engine will not idle down.</b>	Idle set too high.	Adjust idle. Check <i>Specifications</i> page for correct idle speed.
	Engine has an air leak.	Consult with an authorized Shindaiwa servicing dealer.
<b>Cutting attachment moves at engine idle.</b>	Engine idle too high.	Adjust idle. Check <i>Specifications</i> page for correct idle speed.
	Broken clutch spring or worn clutch spring boss.	Replace spring/shoes as required, check idle speed.
<b>Excessive vibration.</b>	Loose attachment holder.	Inspect and re-tighten holders securely.
	Warped or damaged attachment.	Inspect and replace attachment as required.
	Loose gearcase.	Tighten gearcase securely.
	Bent main shaft/worn or damaged bushings.	Inspect and replace as necessary.
<b>Cutting attachment will not move.</b>	Shaft not installed in powerhead or gearcase.	Inspect and reinstall as required.
	Broken shaft.	Consult with an authorized Shindaiwa servicing dealer.
	Damaged gearcase.	

**SHINDAIWA LIMITED WARRANTY STATEMENT FOR  
PRODUCT SOLD IN USA AND CANADA BEGINNING 01/01/2010**

**ECHO, INC'S RESPONSIBILITY**

ECHO Incorporated's (ECHO, INC.) Limited Warranty, provides to the original purchaser that this Shindaiwa product is free from defects in material and workmanship. Under normal use and maintenance from date of purchase, ECHO, INC. agrees to repair or replace at its discretion, any defective product free of charge at any authorized Shindaiwa servicing dealer within listed below application time periods, limitations and exclusions. **THIS LIMITED WARRANTY IS ONLY APPLICABLE TO SHINDAIWA PRODUCTS SOLD BY AUTHORIZED SHINDAIWA DEALERS. IT IS EXTENDED TO THE ORIGINAL PURCHASER ONLY, AND IS NOT TRANSFERABLE TO SUBSEQUENT OWNERS EXCEPT FOR EMISSION RELATED PARTS.** Repair parts and accessories replaced under this warranty are warranted only for the balance of the original unit or accessory warranty period. Any damage caused by improper installation or improper maintenance is not covered by this warranty. All parts or products replaced under warranty become the property of ECHO, INC. This warranty is separate from the Emission control warranty statement supplied with your new product. Please consult the Emission Control Warranty Statement for details regarding emission related parts. For a list of Authorized Shindaiwa Dealers refer to [WWW.SHINDAIWA.COM](http://WWW.SHINDAIWA.COM) or call **1-877-986-7783**.

**OWNER'S RESPONSIBILITY**

To ensure trouble free warranty coverage it is important that you register your Shindaiwa equipment on-line at [WWW.SHINDAIWA.COM](http://WWW.SHINDAIWA.COM) or by filling out the warranty registration card supplied with your unit. Registering your product confirms your warranty coverage and provides a direct link if we find it necessary to contact you.

The owner shall demonstrate reasonable care and use, and follow preventative maintenance, storage, fuel and oil usage as prescribed in the operator's manual. Should a product difficulty occur, you must, at your expense, deliver or ship your Shindaiwa unit to an authorized Shindaiwa servicing dealer for warranty repairs (within the applicable warranty period), and arrange for pick-up or return of your unit after the repairs have been made. For your nearest authorized Shindaiwa servicing dealer, call Shindaiwa's Dealer Referral Center, at 1-877-986-7783 or you can locate a Shindaiwa servicing dealer at [WWW.SHINDAIWA.COM](http://WWW.SHINDAIWA.COM). Should you require assistance or have questions concerning Shindaiwa's Warranty Statement, you can contact our Consumer Product Support Department at 1-800-673-1558 or contact us through the web at [WWW.SHINDAIWA.COM](http://WWW.SHINDAIWA.COM).

**PRODUCT WARRANTY PERIOD**

**RESIDENTIAL APPLICATION**

- **2 YEAR WARRANTY** - Units for residential, or non-income producing use will be covered by this limited warranty for **two (2) years** from date of purchase.

**EXCEPTIONS:**

- For engine powered products, the electronic ignition module, flexible drive cable, and solid drive shaft are warranted for the **life\*** of the product on parts only.
- Cutting attachments such as, but not limited to, bars, chains, sprockets, tines, blades, Power Broom™, belts, and nylon trimmer heads for residential or non-income producing use will be covered for failures due to defects in material or workmanship for a period of **60 days** from original product purchase date. Any misuse from contact with concrete, rocks, or other structures is not covered by this warranty.
- Multipurpose Tool Attachments carry the same warranty duration as the units they are designed to fit.

**COMMERCIAL APPLICATION**

- **90 DAY WARRANTY** - All Chain Saws and Cut-Off Saws for commercial, institutional, agricultural, industrial, or income producing use will be covered by this limited warranty for **90 Days** from the date of purchase.
- **2 YEAR WARRANTY** - Units for commercial, institutional, agricultural, industrial, or income producing use will be covered by this limited warranty for **two (2) years** from the date of purchase.

**EXCEPTIONS:**

- For engine powered products, the electronic ignition module, flexible drive cables, and solid drive shafts are warranted for the **life\*** of the product on parts only.
- Cutting attachments such as, but not limited to, bars, chains, sprockets, tines, blades, Power Broom™, belts, and nylon trimmer heads for commercial, institutional, agricultural, industrial, rental, or income producing will be covered for failures due to defects in material or workmanship for a period of **30 days** from original product purchase date. Any misuse from contact with concrete, rocks, or other structures is not covered by this warranty.
- Multipurpose Tool Attachments carry the same warranty duration as the units they are designed to fit.

**RENTAL APPLICATION - 90 DAYS WARRANTY**

- Units for rental use will be covered against defects in material and workmanship for a period of 90 days from the date of purchase.

\* ECHO INC's liability under the "Lifetime" coverage is limited to furnishing parts specified under the PRODUCT WARRANTY PERIOD section of this warranty statement for "**Life**" free of charge for a period of ten (10) years after the date of the complete unit's final production.

## **PURCHASED REPAIR PARTS AND ACCESSORIES**

- 90-day all applications

## **ATTENTION ENGINE POWERED PRODUCT OWNERS**

This Shindaiwa engine powered product is a quality-engineered unit which has been manufactured to exact tolerances to provide superior performance. To help ensure the performance of the unit, it is required to use engine oil which meets the ISO-L-EGD Standard per ISO/CD 13738 and JASO M345/FD Standards. Shindaiwa Red Armor™ and Shindaiwa One™ are a premium engine oil specifically formulated to meet ISO-L-EGD (ISO/CD 13738) and JASO M345/FD Standards. The use of engine oils designed for other applications, such as for outboard motors or lawnmowers can result in severe engine damage, and will void your engine limited warranty.

## **THIS WARRANTY DOES NOT COVER DAMAGE CAUSED BY:**

- Lack of lubrication or engine failure, due to the use of engine oils that do not meet the ISO-L-EGD (ISO/CD 13738) and JASO M345/FD Standards. Shindaiwa ONE™ Engine Oil meets the ISO-L-EGD and JASO M345/FD Standard. Emission related parts are covered for 2 years regardless of engine oil used, per the statement listed in the EPA or California Emission Control Warranty Explanation.
- Damage caused by use of gasohol, containing methanol (wood alcohol), or gasoline containing less than 89 octane. Only use gasoline which contains 89 octane or higher. Gasohol which contains a **maximum** 10% ethanol (grain alcohol) or 15% MTBE (methyl/tertiary/butyl/ether) is also approved. The prescribed mixing ratio of gasoline to oil is listed on the Shindaiwa oil label and covered in your operator's manual.
- Engine damage caused by use of ether or any starting fluids.
- Damage caused by tampering with engine speed governor or emission components, or running engines above specified and recommended engine speeds as listed in your operator's manual.
- Operation of the unit with improperly maintained/removed cutting shield or removed/damaged air filter.
- Damage caused by dirt, pressure or steam cleaning the unit, salt water, corrosion, rust, varnish, abrasives, and moisture.
- Defects, malfunctions or failures resulting from abuse, misuse, neglect, modifications, alterations, normal wear, improper servicing, or use of unauthorized attachments.
- Incorrect storage procedures, stale fuel, including failure to provide or perform required maintenance services as prescribed in the operator's manual. Preventative maintenance as outlined in the operators manual is the customer's responsibility.
- Failures due to improper set-up, pre-delivery service or repair service by anyone other than authorized Shindaiwa servicing dealer during the warranty period.
- Certain parts and other items are not warranted, including but not limited to: lubricants, starter cords, and engine tune-ups.
- Use of spark plugs other than those meeting performance and durability requirements of the OEM spark plug listed in the Operator's Manuals.
- Overheating or carbon scoring failures due to restricted, clogged exhaust port or combustion chamber, including damage to spark arrester screen.
- Adjustments after the first (30) thirty days and beyond, such as carburetor adjustment and throttle cable adjustment.
- Damage to gears or gear cases caused by contaminated grease or oil, use of incorrect type or viscosity of lubricants, and/or failure to comply with recommended grease or oil change intervals.
- Damage caused by pump or sprayer running dry, pumping or spraying caustic or flammable materials, or lack of or broken strainers.
- Additional damage to parts or components due to continued use after operational problem or failure occurs. Should operational problem or failure occur, the product should not be used, but delivered as is to an authorized Shindaiwa servicing dealer.

It is a dealer's and/or customer's responsibility to complete and return the warranty registration card supplied with your Shindaiwa product or by visiting [WWW.SHINDAIWA.COM](http://WWW.SHINDAIWA.COM). Your receipt of purchase including date, model and serial number must be maintained and presented to an authorized Shindaiwa servicing dealer for warranty service. Proof of purchase rests solely with the customer. Some states do not allow limitations on how long an implied warranty lasts, so the above limitations may not apply to you. Some states do not allow the exclusion or limitation of incidental or consequential damages, so you may also have other specific legal rights which vary from state to state. This limited warranty is given by ECHO Incorporated, 400 Oakwood Rd., Lake Zurich, IL 60047.

## **DISCLAIMER OF IMPLIED WARRANTIES**

This limited warranty is in lieu of all other expressed or implied warranties, including any warranty of FITNESS FOR A PARTICULAR PURPOSE OR USE and any implied warranty of **MERCHANTABILITY** otherwise applicable to this product. ECHO, INC. and its affiliated companies shall not be liable for any special incidental or consequential damage, including lost profits. There are no warranties extended other than as provided herein. This limited warranty may be modified only by ECHO, INC.

**99922201031  
02/05/2010**

**ECHO INCORPORATED EMISSION CONTROL WARRANTY STATEMENT  
FOR ECHO AND SHINDAIWA BRANDS**

The Environmental Protection Agency (EPA) and the California Air Resources Board (C.A.R.B.) and ECHO Incorporated (ECHO Inc.) are pleased to explain the emission control system warranty on your 2010 and later equipment/small off-road engine (SORE). New equipment/SORE must be designed, built and equipped to meet stringent EPA and C.A.R.B. anti-smog standards. ECHO Inc. must warrant the emission control system on your equipment/SORE for the periods of time listed below, provided there has been no abuse, neglect or improper maintenance of your equipment/SORE. Your emission control system may include parts such as: carburetor, fuel-injection system, ignition system, catalytic converter/muffler, fuel tank, fuel feed lines, fuel cap assembly, spark plug, air filters, and other associated components. Where a warrantable condition exists, ECHO Inc will repair your equipment/SORE at no cost to you including diagnosis, parts and labor. The Emission Control System warranty is extended to the original owner including all subsequent owners.

**MANUFACTURER'S WARRANTY COVERAGE:**

The emission control system is warranted for 2 years or the length of the ECHO Inc. warranty, whichever is longer. If any emission-related part on your equipment is defective, the part will be repaired or replaced by ECHO Inc. or its Authorized Service Representative.

**OWNER'S WARRANTY RESPONSIBILITIES:**

As the equipment/SORE owner, you are responsible for the performance of the required maintenance listed in your Operator's Manual. ECHO Inc. recommends that you retain all receipts covering maintenance on your equipment/SORE however, ECHO Inc. cannot deny warranty solely for the lack of receipts or for your failure to ensure the performance of all scheduled maintenance. As the equipment/SORE owner, you should be aware that ECHO Inc. may deny you warranty coverage if your equipment/SORE or a part has failed due to abuse, neglect, improper maintenance or unapproved modifications.

You are responsible for presenting your equipment/SORE to an ECHO Inc. authorized service representative as soon as a problem exists. The warranty repairs should be completed in a reasonable amount of time, not to exceed 30 days. If a warrantable condition exists and there is no Authorized Dealer within 100 miles, ECHO Inc. will pay to ship the unit to the nearest authorized dealer. If you have questions regarding your warranty coverage, you should contact ECHO Inc. at 1-800-673-1558, web site WWW.ECHO-USA.COM or contact Shindaiwa at 1-877-986-7783, web site WWW.SHINDAIWA.COM.

**WHAT DOES THIS WARRANTY COVER?**

ECHO Inc. warrants that your equipment/SORE was designed, built and equipped to conform with applicable EPA and C.A.R.B. emissions standards and that your equipment/SORE is free from defects in material and workmanship that would cause it to fail to conform with applicable requirements for 2 years or the length of the ECHO Inc. warranty, whichever is longer. The warranty period begins on the date the product is purchased by an end user.

**HOW WILL A COVERED PART BE CORRECTED?**

If there is a defect in a part covered by this warranty, any ECHO Inc. Authorized Service Dealer will correct the defect. You will not have to pay anything to have the part adjusted, repaired or replaced. This includes any labor and diagnosis for warranted repairs performed by the dealer. In addition, engine parts not expressly covered under this warranty but whose failure is a result of a failure of a covered part will be warranted.

**WHAT PARTS ARE COVERED?**

Any applicable emission related part not scheduled for "required maintenance" will be repaired or replaced within the warranty period. The repaired or replaced part will be warranted for the remaining ECHO Inc. warranty period.

Any warranted part that is scheduled only for regular inspection in the written instructions supplied is warranted for the warranty period stated above. Any such part repaired or replaced under warranty will be warranted for the remaining ECHO Inc. warranty period.

Any emission related part scheduled for replacement during "required maintenance" is warranted for the period of time prior to the first scheduled replacement point for that part. Any such part repaired or replaced under warranty shall be warranted for the remainder of the period prior to the first scheduled replacement point for that part.

Any manufacturer-approved replacement part may be used in the performance of any warranty maintenance or repairs on emission related parts, and must be provided without charge if the part is still under warranty.

Any replacement part that is equivalent in performance and durability may be used in non-warranty maintenance or repairs, and shall not reduce the warranty obligations of the manufacturer.

Throughout the equipment/SORE warranty period, ECHO Inc. will maintain a supply of warranted parts sufficient to meet the expected demand for such parts.

**SPECIFIC EMISSION RELATED WARRANTED PARTS:**

- Electronic Ignition System
- Catalytic Converter / Muffler Assembly
- Choke
- Fuel Tank
- Air Filter
- Spark Plug
- Carburetor (complete assembly or replaceable components)
- Fuel-Injection Assembly (or replaceable components)
- Fuel Cap Assembly
- Fuel Feed Line (and associated clamps/connectors as applicable)

**WHAT IS NOT COVERED?**

Any failure caused by abuse, neglect, improper maintenance, unapproved modifications, use of unapproved add-on parts/modified parts or unapproved accessories.

This Emission Control Warranty is valid only for the U.S.A., it's Territories, and Canada.

**99922201033  
01/2010**











## **Servicing Information**

### **Parts/Serial Number**

Genuine Shindaiwa Parts and Assemblies for your Shindaiwa products are available only from an Authorized Shindaiwa Dealer. When you do need to buy parts **always** have the Model Number, Type and Serial Number of the unit with you. You can find these numbers on the engine. For future reference, write them in the space provided below.

### **Service**

Service of this product during the warranty period must be performed by an Authorized Shindaiwa Service Dealer. For the name and address of the Authorized Shindaiwa Service Dealer nearest you, ask your retailer or call: 1-877-986-7783. Dealer information is also available on [WWW.SHINDAIWA.COM](http://WWW.SHINDAIWA.COM). When presenting your unit for Warranty service/repairs, proof of purchase is required.

### **Consumer Product Support**

If you require assistance or have questions concerning the application, operation or maintenance of this product you may call the Shindaiwa Consumer Product Support Department at 1-877-986-7783 from 8:30 am to 4:30 pm (Central Standard Time) Monday through Friday. Before calling, please know the model and serial number of your unit.

### **Warranty Registration**

To ensure trouble free warranty coverage it is important that you register your Shindaiwa equipment by filling out the warranty registration card supplied with your unit. Registering your product confirms your warranty coverage and provides a direct link if we find it necessary to contact you.

### **Additional or Replacement Manuals**

Replacement Operator and Parts Catalogs are available from your Shindaiwa dealer or at [WWW.SHINDAIWA.COM](http://WWW.SHINDAIWA.COM) or by contacting the Consumer Product Support Department (1-877-986-7783). Always check [WWW.SHINDAIWA.COM](http://WWW.SHINDAIWA.COM) for updated information.

# **shindaiwa®**

ECHO Incorporated.  
400 Oakwood Road  
Lake Zurich, IL 60047-1564 U.S.A.  
Telephone: 1-877-986-7783  
Fax: 1-847-540-8416  
[www.shindaiwa.com](http://www.shindaiwa.com)

Yamabiko Corporation  
7-2 Suehirocho 1-Chome, Ohme,  
Tokyo, 198-8760, Japan  
Phone: 81-428-32-6118  
Fax: 81-428-32-6145